

SGDV-□, SGMJV-□, SGMJV-□, SGMJV-□, SGMJV-□, SGMJV-□, SGMJV-□

Sigma-5 servo system

The High performance servo family for motion control. Compact size, reduced space and integrated MECHATROLINK-II.

- Advance autotuning function
- Enhanced vibration suppression function
- Standard support for analog voltage/pulse train reference series or MECHATROLINK-II communications reference series.
- Support for direct drive servomotors, linear servomotors and linear sliders
- Integrated safety stop function
- Oscilloscope available via software tool
- Windows based configuration and commissioning software

Ratings

- 230 VAC Single-phase 50 W to 1.5 kW (4.77 Nm)
- 400 VAC Three-phase 500 W to 5 kW (28.4 Nm)



System configuration

(Refer to chapter Sigma-II rotary motors)

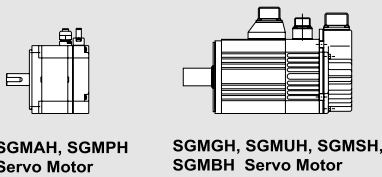

(Refer to chapter Sigma-5 rotary motors)

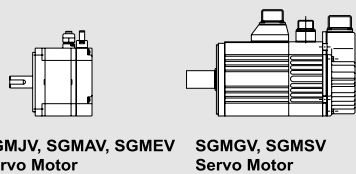

(Refer to chapter Sigma linear motors)

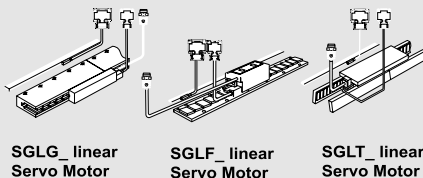

(Refer to chapter Sigma direct drive motors)

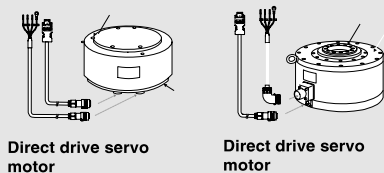

Sigma-5 Analog/Pulse Reference Servo Drive

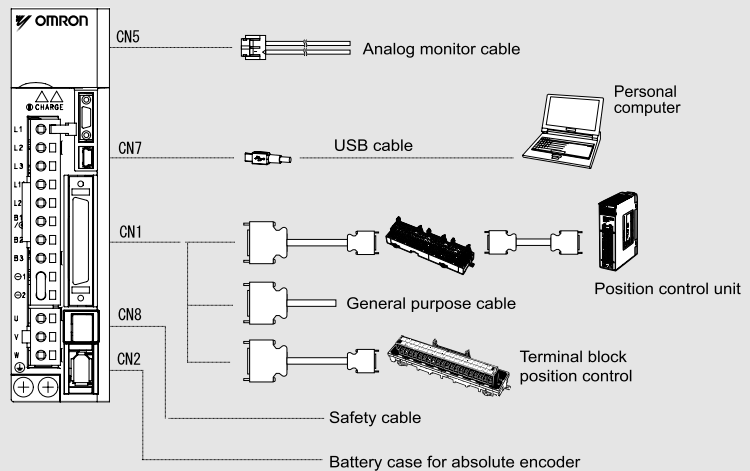

Sigma-5 MECHATROLINK-II Servo Drive

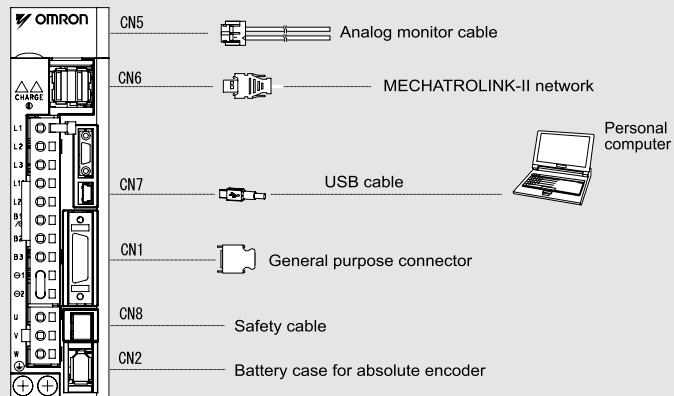

Type designation

Servo drive

SGDV - 04 A 01 A - OY - □

Sigma-5 servo drive

Capacity

Voltage	Code	Output
230 V	A5	50 W
	01	100 W
	02	200 W
	04	400 W
	08	750 W
400 V	15	1.5 kW
	05	500 W
	10	1.0 kW
	15	1.5 kW
	20	2.0 kW
	30	3.0 kW
	50	5.0 kW

Source voltage

- A: 230 V
- D: 400 V

Code	Specifications
Blank	Standard
008000	Servo drive 1.5 kW single-phase 230 V

Omron-Yaskawa Motion Control B.V.

Design Revision Order: A, B...

Interface

Code	Specifications
01	Analog voltage/pulse train reference type (for rotary servomotors)
05	Analog voltage/pulse train reference type (for linear servomotors)
11	MECHATROLINK-II comms reference type (for rotary servomotors)
15	MECHATROLINK-II comms reference type (for linear servomotors)

Servo drive specifications

Single-phase, 230 V

Servo drive type	SGDV-□	A5A□□A-OY	01A□□A-OY	02A□□A-OY	04A□□A-OY	08A□□A-OY	15A□□A-OY-008000
Applicable servo motor	SGMAH-□	A3A□□/A5A□	01A□	02A□	04A□	08A□	-
	SGMPH-□	-	01A□	02A□	04A□	08A□	15A□
	SGMJV-□	A5A□	01A□	02A□	04A□	08A□	-
	SGMAV-□	A5A□	01A□	C2A□□/02A□	04A□	06A□□/08A□	10A□
	SGMEV-□	-	01A□	02A□	04A□	08A□	15A□
Max. applicable motor capacity	W	50	100	200	400	750	1500
Continuous output current	Arms	0.66	0.91	1.6	2.8	5.5	11.6
Max. output current	Arms	2.1	2.9	6.5	9.3	16.9	28
Input power	Main circuit	Single-phase, 200 to 230 VAC + 10 to -15% (50/60 Hz)					
Supply	Control circuit	Single-phase, 200 to 230 VAC + 10 to -15% (50/60 Hz)					
Control method		Single phase full-wave rectification / IGBT / PWM / sine-wave current drive method					
Feedback		Serial encoder (incremental/absolute)					
Conditions	Usage/storage temperature	0 to +55 °C / -20 to 85 °C					
	Usage/storage humidity	90%RH or less (non-condensing)					
	Altitude	1000m or less above sea level					
	Vibration/shock resistance	4.9 m/s ² / 19.6 m/s ²					
Configuration		Base mounted					
Approx. weight	Kg		0.9		1.0	1.5	2.8

Three-phase, 400 V

Servo drive type	SGDV-□	05D□□A-OY	10D□□A-OY	15D□□A-OY	20D□□A-OY	30D□□A-OY	50D□□A-OY
Applicable servo motor	SGMAH-□	03D□	07D□	-	-	-	-
	SGMPH-□	02D□□/04D□	08D□	15D□	-	-	-
	SGMGH-□	05D□	09D□	13D□	20D□	30D□	44D□
	SGMSH-□	-	10D□	15D□	20D□	30D□	40D□/50D□
	SGMUH-□	-	10D□	15D□	-	30D□	40D□
	SGMEV-□	02/03/04D□	07D□/08D□	15D□	-	-	-
	SGMGV-□	03D□/05D□	09D□	13D□	20D□	30D□	44D□
	SGMSV-□	-	10D□	15D□	20D□	25D□	40D□/50D□
Max. applicable motor capacity	kW	0.5	1.0	1.5	2.0	3.0	5.0
Continuous output current	Arms	1.9	3.5	5.4	8.4	11.9	16.5
Max. output current	Arms	5.5	8.5	14	20	28	42
Input power	Main circuit	Three-phase, 380 to 480 VAC + 10 to -15% (50/60Hz)					
Supply	Control circuit	24 VDC +/-15%					
Control method		Three phase full-wave rectification / IGBT / PWM / sine-wave current drive method					
Feedback		Serial encoder (incremental/absolute)					
Conditions	Usage/storage temperature	0 to +55 °C / -20 to +85 °C					
	Usage/storage humidity	90%RH or less (non-condensing)					
	Altitude	1000 m or less above sea level					
	Vibration/shock resistance	4.9 m/s ² / 19.6 m/s ²					
Configuration		Base mounted					
Approx. weight	Kg		2.7			3.7	5.6

Sigma-5 Analog/Pulse Reference Servo Drive

General specifications

Speed/torque control mode	Performance	Speed control range	1:5000	
		Speed variance	Load variance	During 0 to 100% load $\pm 0.01\%$ max. (at rated speed)
			Voltage variance	Rated voltage $\pm 10\%:0\%$ (at rated speed)
			Temperature variance	25 ± 25 °C: $\pm 0.1\%$ max. (at rated speed)
	Frequency characteristics	1.6 kHz		
	Torque control accuracy (Repeatability)	$\pm 1\%$		
	Soft start time setting	0 to 10 s (acceleration, deceleration can each be set.)		
	Input signal	Speed reference input	Reference voltage	± 6 VDC (forward motor rotation if positive reference) at rated speed: Set at delivery Variable setting range: ± 2 to ± 10 VDC at rated speed/ max. input voltage: ± 12 V
			Input impedance	Approx. 14 k Ω
			Circuit time constant	Approx. 30 μ s
Torque reference input		Reference voltage	± 3 VDC (forward rotation if positive reference) at rated torque: Set at delivery Variable setting range ± 1 to ± 10 VDC at rated torque reference, max. input voltage: ± 12 V	
		Input impedance	Approx. 14 k Ω	
		Circuit time constant	Approx. 30 μ s	
Position control mode	performance	Feedforward compensation	0 to 100% (setting resolution: 1%)	
		Position completed width setting	0 to 1073741824 command units (setting resolution: 1 command unit)	
	Input signal	Command pulse	Input pulse type	Sign + pulse train, 90° phase displacement 2-phase pulse (A-phase+ B-phase) or CCW/CW pulse train
			Input pulse form	Non-insulated line driver (+5 V level) , open collector.
Input pulse frequency			0 to 4 Mpps (200 Kpps max. at open collector)	
Control signal	Clears error pulse by external signal			
I/O signal	Position signal output	A-phase, B.phase, C-phase: line driver output.		
	Sequence input signal	Servo ON, P control (or control mode switching, forward/reverse motor rotation by internal speed setting, zero clamp, command pulse inhibit), forward/reverse run prohibit, forward/reverse current limit (or internal speed switching), alarm reset.		
	Sequence output signal	Servo alarm, alarm codes (3-bit output): CN1 output terminal is fixed It is possible to output three types of signal form incl.: positioning complete, speed coincidence detection, servo-motor rotation detection, servo ready, current limit detection, speed limit detection, brake release, warning, NEAR.		
Integrated functions	USB Communications	Interface	Personal computer	
		Communications standard	Compliant with USB1.1 standard (12 Mbps)	
		Function	Status display, parameter settings, adjustment functions, utility functions, alarm traceback display, JOG run/autotuning operations and graphing functions for speed/torque command signal, etc	
	Automatic load inertia detection	Automatic motor parameter setting. One parameter rigidity setting.		
	Dynamic brake (DB)	Operates during main power OFF, servo alarm, servo OFF or overtravel		
	Regenerative processing	Internal resistor included in models from 500 W to 5 kW. Regenerative resistor externally mounted (option).		
	Overtravel (OT) prevention function	DB stop, deceleration stop or coast to stop during P-OT, N-OT operation		
	Encoder divider function	Optional division pulses possible		
	Electronic gearing	0,01 < Numerator/Denominator < 100		
	Internal speed setting function	3 speeds may be set internally		
	Protective functions	Overcurrent, overvoltage, low voltage, overload, regenerative error		
	Analog monitor functions for supervision	Integrates analog monitor connector for supervision of the speed and torque reference signals, etc. Number of channels: 2 (Output voltage: +/-10V DC)		
	Panel operator	Display functions	CHARGE, 7-segments LEDx5	
		Panel operator keys	Used to set parameters (4 keys)	
	Safety functions	Hard wire base block signal and status monitor (fixed output) of safety circuit		
Others	Reverse connection, zero search, automatic motor discrimination function, and DC reactor connection terminal for high frequency power suppression function.			

Sigma-5 MECHATROLINK-II Servo Drives

General specifications

Position/speed/torque control mode	Speed control range		1:5000	
	Performance	Speed variance	Load variance	During 0 to 100% load $\pm 0.01\%$ max. (at rated speed)
			Voltage variance	Rated voltage $\pm 10\%:0\%$ (at rated speed)
			Temperature variance	25 \pm 25 °C: $\pm 0.1\%$ max. (at rated speed)
	Frequency characteristics		1.6 kHz	
	Torque control accuracy (Repeatability)		$\pm 1\%$	
	Soft start time setting		0 to 10 s (acceleration, deceleration can each be set.)	
	Command input	MECHATROLINK Communication		MECHATROLINK-II commands (for sequence, motion, data setting/reference, monitor, adjustment and other commands)
	I/O signal	Position signal output		A-phase, B-phase, C-phase: line driver output.
Sequence input signal		Homing deceleration limit switch, forward/reverse run prohibited, external latch signals, forward/reverse current limit.		
Sequence output signal		It is possible to output three types of signal form incl.: positioning complete, speed coincidence detection, servo-motor rotation detection, servo ready, current limit detection, speed limit detection, brake release, warning, NEAR.		
Communications	USB Communications	Interface	Personal computer	
		Communications standard	Compliant with USB1.1 standard (12 Mbps)	
	Mechatrolink Communications	Function	Status display, parameter setting, adjusting functions, utility functions, alarm traceback display, JOG run/autotuning operations and graphing functions for speed/torque command signal, etc	
		Communications protocol	MECHATROLINK-II	
		Station Address	41H to 5FH (max. number of slaves: 30)	
		Transmission Speed	10 Mbps	
		Transmission Cycle	250 μ s, 0.5 to 4.0 ms (multiple of 0.5 ms)	
		Data length	17-bytes and 32-bytes	
	Integrated functions	Automatic load inertia detection		Automatic motor parameter setting. One parameter rigidity setting.
		Dynamic brake (DB)		Operates during main power OFF, servo alarm, servo OFF or overtravel
Regenerative processing		Internal resistor included in models from 500 W to 5 kW. Regenerative resistor externally mounted (option).		
Overtravel (OT) prevention function		DB stop, deceleration stop or coast to stop during P-OT, N-OT operation		
Encoder divider function		Optional division pulses possible		
Electronic gearing		0,01 < Numerator/Denominator < 100		
Internal speed setting function		3 speeds may be set internally		
Protective functions		Overcurrent, overvoltage, low voltage, overload, regeneration error		
Analog monitor functions for supervision		Integrates analog monitor connectors for supervision of the speed and torque reference signals, etc. Number of channels: 2 (Output voltage: +/-10V DC).		
Panel operator		Display functions	CHARGE, 7-segments LEDX1	
	Switches	Rotary switch: MECHATROLINK-II station address setting (16 channels) DIP switch: MECHATROLINK-II communications setting (4 channels)		
Safety functions		Hard wire base block signal and status monitor (fixed output) of safety circuit		
Others		Reverse connection, zero search, automatic motor discrimination function, and DC reactor connection terminal for high frequency power suppression function.		

Type designation

Servo motor

SGMJV - 01 A 1 A 6 S - OY

Omron-Yaskawa Motion Control B.V.

Sigma-5 servo motor type
 SGMJV: Middle-inertia
 SGMVAV: Low-inertia and high dynamics
 SGMEV: Flat type
 SGMGV: High-torque type
 SGMSV: Low-inertia and high dynamics

Capacity (kW)

Code	SGMJV	SGMAV	SGMEV	SGMGV	SGMSV
	3000 min ⁻¹	3000 min ⁻¹	3000 min ⁻¹	1500 min ⁻¹	3000 min ⁻¹
A5	0.05	0.05			
01	0.1	0.1	0.1		
C2		0.15			
02	0.2	0.2	0.2		
03			0.3	0.3	
04	0.4	0.4	0.4		
05				0.45	
06		0.55			
07			0.65		
08	0.75	0.75	0.75		
09				0.85	
10		1.0			1.0
13				1.3	
15			1.5		1.5
20				1.8	2.0
25					2.5
30				2.9	3.0
40					4.0
44				4.4	
50					5.0
60					
70					
75					
1A					
1E					

Voltage

Code	Voltage	Type				
		SGMJV	SGMAV	SGMEV	SGMGV	SGMSV
A	230 V	○	○	○		
D	400 V			○	○	○

Brake, oil seal specifications

Code	Options	Type				
		SGMJV	SGMAV	SGMEV	SGMGV	SGMSV
1	No brake, no oil/dust seal	◎	◎	◎	○	○
B	90 VDC brake			○	○	
C	24 VDC brake	○	○	○	○	
D	Oil seal + 90 VDC brake			○	○	
E	Oil seal + 24 VDC brake	○	○	○	○	
F	Dust seal			○	◎	◎
G	Dust seal + 90 VDC brake			○		
H	Dust seal + 24 VDC brake			○		
S	Oil seal	○	○	○	○	

◎: Standard ○: Option

Shaft end specifications

Code	Shaft end	Type				
		SGMJV	SGMAV	SGMEV	SGMGV	SGMSV
2	Straight, no key	○	○	○	○	○
6	Straight, key, tapped	◎	◎	◎	◎	◎
8	Straight, no key, tapped	○	○	○		
B	With two flat seats	○	○	○		

◎: Standard ○: Option

Design Revision Order:

- A: Standard
- E: IP67 (SGMEV-01, 02, 04, 08, 15)
- F: Prepared for oil seal mounting (SGMEV-03, 07)

Serial encoder specifications

Code	Encoder	Type				
		SGMJV	SGMAV	SGMEV	SGMGV	SGMSV
A	13-bit incremental	○				
D	20-bit incremental	◎	◎	◎	◎	◎
3	20-bit absolute	○	○	○	○	○

◎: Standard ○: Option

Servo motor specifications

Type SGMJV, 230 V

Ratings and specifications

Applied voltage		230 V						
Servo motor model SGMJV-□		A5A□	01A□	02A□	04A□	08A□		
Rated output ^{*1}	W	50	100	200	400	750		
Rated torque ^{*1,2}	N·m	0.159	0.318	0.637	1.27	2.39		
Instantaneous peak torque ^{*1}	N·m	0.557	1.11	2.23	4.46	8.36		
Rated current ^{*1}	A (rms)	0.61	0.84	1.6	2.7	4.7		
Instantaneous max. current ^{*1}	A (rms)	2.1	2.9	5.8	9.3	16.9		
Rated speed ^{*1}	min ⁻¹	3000						
Max. speed ^{*1}	min ⁻¹	6000						
Torque constant	N·m/A (rms)	0.285	0.413	0.435	0.512	0.544		
Rotor moment of inertia (JM)	kg·m ² ×10 ⁻⁴ (without brake)	0.0414	0.0665	0.259	0.442	1.57		
	kg·m ² ×10 ⁻⁴ (with brake)	0.0489	0.0740	0.323	0.506	1.74		
Allowable load moment of inertia (JL)	Multiple of (JM)	15			10			
Rated power rate ^{*1}	kW/s	6.11	15.2	15.7	36.5	36.3		
Rated angular acceleration ^{*1}	rad/s ²	38400	47800	24600	28800	15200		
Encoder	Standard	Incremental encoder (20 bits)						
	Option	Incremental encoder (13 bits)/ Absolute encoder (20 bits)						
Allowable radial load	N	78		245		392		
Allowable thrust load	N	54			74		147	
Approx. mass	Kg (without brake)	0.3	0.4	0.9	1.3	2.7		
	Kg (with brake)	0.6	0.7	1.5	1.9	3.6		
Brake specifications	Rated voltage	24 VDC						
	Power consumption (at 20°C)	W	6		6.9		7.7	
	Current consumption (at 20°C)	A	0.25			0.29		0.32
	Holding torque	N·m	0.159	0.318	0.637	1.27	2.39	
	Rise time for holding torque	ms (max)	100					
	Release time	ms (max)	60				80	
Basic specifications	Time rating	Continuous						
	Thermal class	Class B						
	Usage/ storage temperature	0 to +40 °C/ -20 to 60 °C without freezing						
	Usage/ storage humidity	20 to 80% RH (non-condensing)						
	Vibration class	15 µm or below						
	Insulation resistance	500 VDC, 10 MOhm min.						
	Withstand voltage	1500 VAC for one minute						
	Enclosure	Totally-enclosed, self-cooled, IP65 (excluding shaft opening)						
	Vibration resistance	Vibration acceleration 49 m/s ²						
	Altitude	1000 m or less above sea level						
	Mounting	Flange-mounted						

Note: *1. These items and torque/speed characteristics quoted in combination with an SGD servo drive are at an armature winding temperature of 100°C. Other values quoted are at 20°C.

*2. The rated torques listed here are the values for the continuous allowable torque at 40°C with an aluminium heatsink of the following dimensions attached: SGMJV-A5/01: 200 mm x 200 mm x 6 mm, SGMJV-02/04/08: 250 mm x 250 mm x 6 mm

Torque-speed characteristics

(A : Continuous duty zone B : Intermittent duty zone)

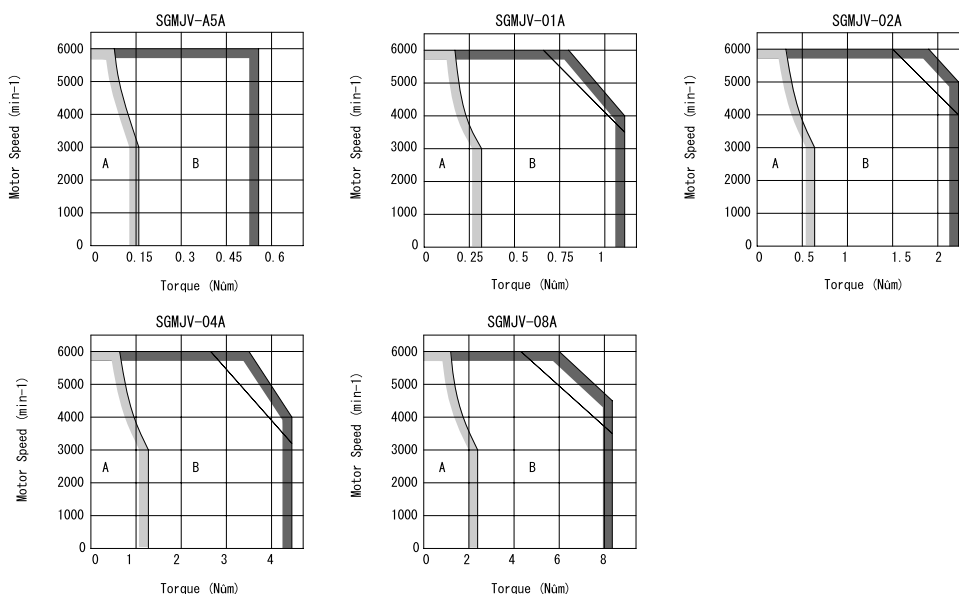

Type SGMV, 230 V

Ratings and specifications

Applied voltage		230 V									
Servo motor model SGMV-□		A5A□	01A□	C2A□	02A□	04A□	06A□	08A□	10A□		
Rated output ¹	W	50	100	150	200	400	550	750	1000		
Rated torque ^{1,2}	N·m	0.159	0.318	0.477	0.637	1.27	1.75	2.39	3.18		
Instantaneous peak torque ¹	N·m	0.477	0.955	1.43	1.91	3.82	5.25	7.16	9.55		
Rated current ¹	A (rms)	0.66	0.91	1.3	1.5	2.6	3.8	5.3	7.4		
Instantaneous max. current ¹	A (rms)	2.1	2.8	4.2	5.3	8.5	12.2	16.6	23.9		
Rated speed ¹	min ⁻¹	3000									
Max. speed ¹	min ⁻¹	6000									
Torque constant	N·m/A (rms)	0.265	0.375	0.381	0.450	0.539	0.496	0.487	0.467		
Rotor moment of inertia (JM)	kg·m ² ×10 ⁻⁴ (without brake)	0.0242	0.0380	0.0531	0.116	0.190	0.326	0.769	1.2		
	kg·m ² ×10 ⁻⁴ (with brake)	0.0312	0.0450	0.0601	0.180	0.254	0.390	0.940	1.41		
Allowable load moment of inertia (JL)	Multiple of (JM)	30				20			10		
Rated power rate ¹	kW/s	10.4	26.6	42.8	35.0	84.9	93.9	74.1	84.3		
Rated angular acceleration ¹	rad/s ²	65800	83800	89900	54900	67000	53700	31000	26500		
Encoder	Standard	Incremental encoder (20 bits)									
	Option	Absolute encoder (20 bits)									
Allowable radial load	N	68	78		245			392			
Allowable thrust load	N	54			74			147			
Approx. mass	Kg (without brake)	0.3	0.4	0.5	0.9	1.2	1.7	2.3	3.6		
	Kg (with brake)	0.6	0.7	0.8	1.5	1.8	2.4	3.2	4.6		
Brake specifications	Rated voltage	24 VDC									
	Power consumption (at 20°C)	6			6.9		8.7	7.7	7		
	Current consumption (at 20°C)	A			0.25		0.29	0.36	0.32	0.29	
	Holding torque	N·m		0.159	0.318	0.477	0.637	1.27	1.75	2.39	3.18
	Rise time for holding torque	ms (max)								100	
	Release time	ms (max)							60	80	
Basic specifications	Time rating	Continuous									
	Thermal class	Class B									
	Usage/ storage temperature	0 to +40 °C/ -20 to 60 °C without freezing									
	Usage/ storage humidity	20 to 80% RH (non-condensing)									
	Vibration class	15 µm or below									
	Insulation resistance	500 VDC, 10 MΩ min.									
	Withstand voltage	1500 VAC for one minute									
	Enclosure	Totally-enclosed, self-cooled, IP65 (excluding shaft opening)									
	Vibration resistance	Vibration acceleration 49 m/s ²									
	Altitude	1000 m or less above sea level									
Mounting	Flange-mounted										

Note: *1. These items and torque/speed characteristics quoted in combination with an SGD servo drive are at an armature winding temperature of 100°C. Other values quoted are at 20°C.

*2. The rated torques listed here are the values for the continuous allowable torque at 40°C with an aluminium heatsink of the following dimensions attached (SGMJV-A5/01:200 mm x 200 mm x 6 mm, SGMJV-02/04/08:250 mm x 250 mm x 6 mm).

Torque-speed characteristics

(A : Continuous duty zone B : Intermittent duty zone)

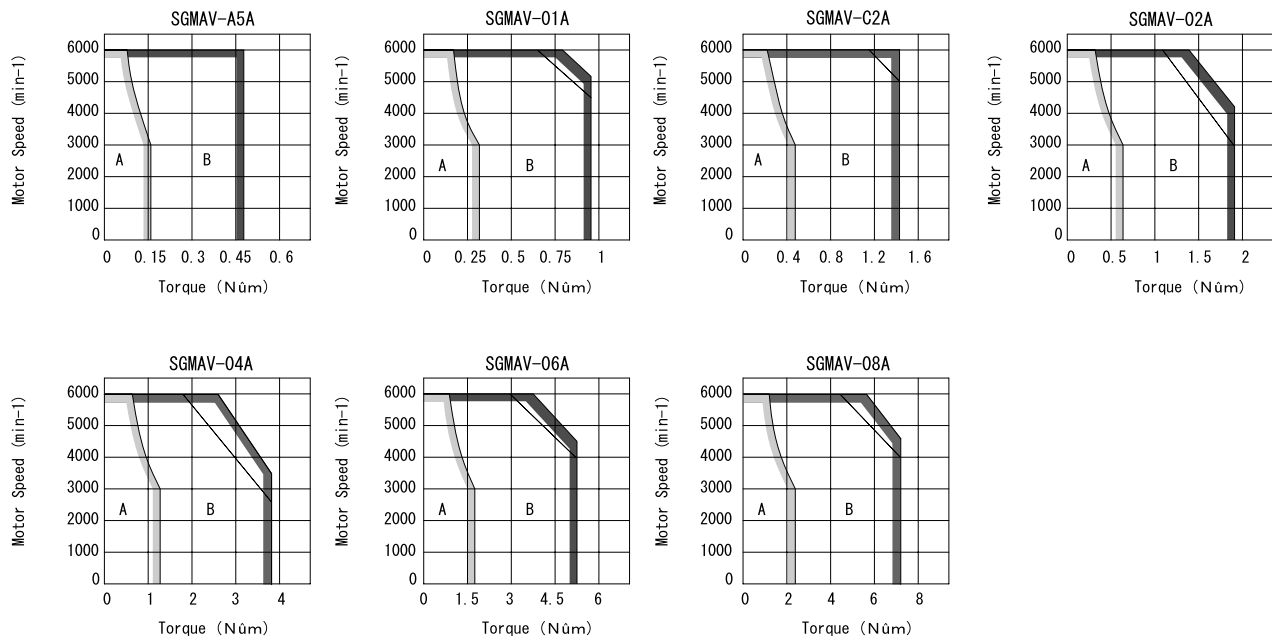

Type SGMEV, 230 V/400 V

Ratings and specifications

Applied voltage		230 V					400 V					
Servo motor model SGMEV-□		01A□	02A□	04A□	08A□	15A□	02D□	03D□	04D□	07D□	08D□	15D□
Rated output ¹	W	100	200	400	750	1500	200	300	400	650	750	1500
Rated torque ^{1,2}	N·m	0.318	0.637	1.27	2.39	4.77	0.637	0.955	1.27	2.07	2.39	4.77
Instantaneous peak torque ¹	N·m	0.955	1.91	3.82	7.16	14.3	0.191	3.82	3.82	7.16	7.16	14.3
Rated current ¹	A (rms)	0.89	2.0	2.6	4.1	7.5	1.4	1.3	1.4	2.2	2.6	4.5
Instantaneous max. current ¹	A (rms)	2.8	6.5	8.5	13.9	23.0	4.5	5.1	4.4	8.4	7.8	13.7
Rated speed ¹	min ⁻¹	3000										
Max. speed ¹	min ⁻¹	5000										
Torque constant	N·m/A (rms)	0.392	0.349	0.535	0.641	0.687	0.481	0.837	0.963	1.02	0.994	1.135
Rotor moment of inertia (JM)	kg·m ² ×10 ⁻⁴ (without brake)	0.049	0.193	0.331	2.1	4.02	0.193	0.173	0.331	0.672	2.1	4.02
	kg·m ² ×10 ⁻⁴ (with brake)	0.078	0.302	0.440	2.975	4.895	0.302	0.231	0.440	0.812	2.975	4.895
Allowable load moment of inertia (JL)	Multiple of (JM)	25	15	7	5		15	20	7	20	5	
Rated power rate ¹	kW/s	20.6	21.0	49.0	27.1	56.7	21	52.9	49.0	63.8	27.1	56.7
Rated angular acceleration ¹	rad/s ²	64800	33000	38500	11400	11900	33000	55300	38500	30800	11400	11900
Encoder	Standard	Incremental encoder (20 bits)										
	Option	Absolute encoder (20 bits)										
Allowable radial load	N	78	245		392	490	245	345	245	392		490
Allowable thrust load	N	49	68		147		68	74	68	147		
Approx. mass	Kg (without brake)	0.7	1.4	2.1	4.2	6.6	1.4	1.7	2.1	3.4	4.2	6.6
	Kg (with brake)	0.9	1.9	2.6	5.7	8.1	1.9	2.2	2.6	4.3	5.7	8.1
Holding brake moment of inertia J	kg·m ² ×10 ⁻⁴	0.029	0.109		0.875		0.109	0.058	0.109	0.140	0.875	
Basic specifications	Time rating	Continuous										
	Thermal class	Class B										
	Usage/ storage temperature	0 to +40 °C/ -20 to 60 °C without freezing										
	Usage/ storage humidity	20 to 80% RH (non-condensing)										
	Vibration class	15 μm or below										
	Insulation resistance	500 VDC, 10 MOhm min.										
	Withstand voltage	1500 VAC for one minute										
	Enclosure	Totally-enclosed, self-cooled, IP55 ³										
	Vibration resistance	Vibration acceleration xx m/s ²										
	Altitude	1000 m or less above sea level										
Mounting	Flange-mounted											

Note: *1. These items and torque/speed characteristics quoted in combination with an SGD servo drive are at an armature winding temperature of 100°C. Other values quoted are at 20°C.

*2. The rated torques listed here are the values for the continuous allowable torque at 40°C with an aluminium heatsink of the following dimensions attached (SGMEV-01A/02A/04A/02D/03D/04D/07D: 250 mm x 250 mm x 6 mm, SGMEV-08A/15A/08D/15D: 300 mm x 300 mm x 12 mm)

*3. IP55 in case of standard cable attaching. IP67 is possible unless SGMEV-03D/07D servomotors.

Torque-speed characteristics

(A : Continuous Duty Zone B : Intermittent Duty Zone)

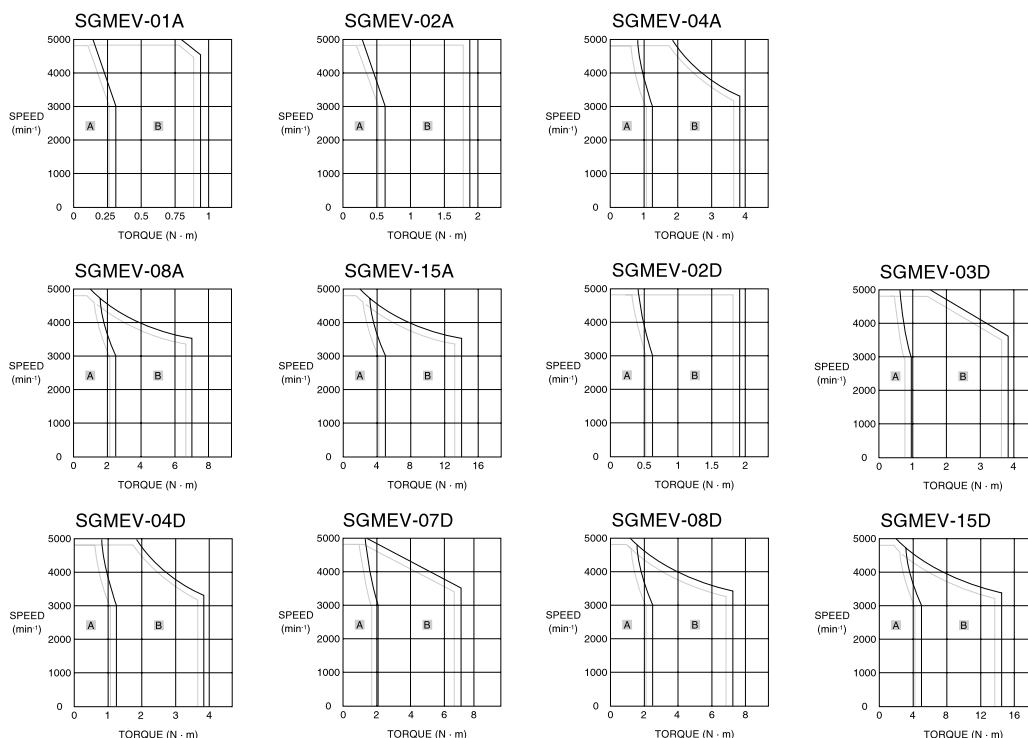

Type SGMGV, 400 V

Ratings and specifications

Applied voltage		400 V							
Servo motor model SGMGV-□		03D□	05D□	09D□	13D□	20D□	30D□	44D□	
Rated output ^{*1}	kW	0.3	0.45	0.85	1.3	1.8	2.9	4.4	
Rated torque ^{*1}	N·m	1.96	2.86	5.39	8.34	11.5	18.6	28.4	
Instantaneous peak torque ^{*1}	N·m	5.88	8.92	13.8	23.3	28.7	45.1	71.1	
Rated current ^{*1}	A (rms)	1.4	1.9	3.5	5.4	8.4	11.9	16.5	
Instantaneous max. current ^{*1}	A (rms)	4	5.5	8.5	14	20	28	40.5	
Rated speed ^{*1}	min ⁻¹	1500							
Max. speed ^{*1}	min ⁻¹	3000							
Torque constant	N·m/A (rms)	1.55	1.71	1.72	1.78	1.50	1.70	1.93	
Rotor moment of inertia (JM)	kg·m ² ×10 ⁻⁴ (without brake)	2.48	3.33	13.9	19.9	26	46	67.5	
	kg·m ² ×10 ⁻⁴ (with brake)	2.69	3.54	16	22	28.1	54.5	76	
Allowable load moment of inertia (JL)	Multiple of (JM)	5							
Rated power rate ^{*1}	kW/s (without brake)	15.5	24.6	20.9	35.0	50.9	75.2	119	
	kW/s (with brake)	14.3	23.1	18.2	31.6	47.1	63.5	106	
Rated angular acceleration ^{*1}	rad/s ² (without brake)	7900	8590	3880	4190	4420	4040	4210	
	rad/s ² (with brake)	7290	8080	3370	3790	4090	3410	3740	
Encoder	Standard	Incremental encoder (20 bits)							
	Option	Absolute encoder (20 bits)							
Allowable radial load	N	490			686	980	1470		
Allowable thrust load	N	98			343	392	490		
Approx. mass	Kg (without brake)	2.6	3.2	5.5	7.1	8.6	13.4	17.5	
	Kg (with brake)	4.5	5.0	7.5	9.0	11.0	19.5	23.5	
Brake specifications	Rated voltage	24 /90 VDC							
	Power consumption (at 20°C)	W (24 VDC)	10			9.8		18.5	
		W (90 VDC)	10			10.1		18.5	
	Current consumption (at 20°C)	A (24 VDC)	0.42			0.41		0.77	
		A (90 VDC)				0.11		0.21	
	Holding torque	N·m	4.5		12.7	19.6		43.1	
	Rise time for holding torque	ms (max)	80					100 (24 V), 80 (90 V)	
Release time	ms (max)	100					170		
Basic specifications	Time rating	Continuous							
	Thermal class	Class F							
	Usage/ storage temperature	0 to +40 °C/ -20 to 60 °C without freezing							
	Usage/ storage humidity	20 to 80% RH (non-condensing)							
	Insulation resistance	500 VDC, 10 MOhm min.							
	Withstand voltage	1500 VAC for one minute							
	Vibration class	15 µm or below							
	Enclosure	Totally-enclosed, self-cooled, IP67 (excluding shaft opening)							
	Vibration resistance	Vibration acceleration 24.5 m/s ²							
	Altitude	1000 m or less above sea level							
Mounting	Flange-mounted								

Note: *1. These items and torque/speed characteristics quoted in combination with an SGDv servo drive are at an armature winding temperature of 20°C.

Torque-speed characteristics

(A : Continuous duty zone B : Intermittent duty zone)

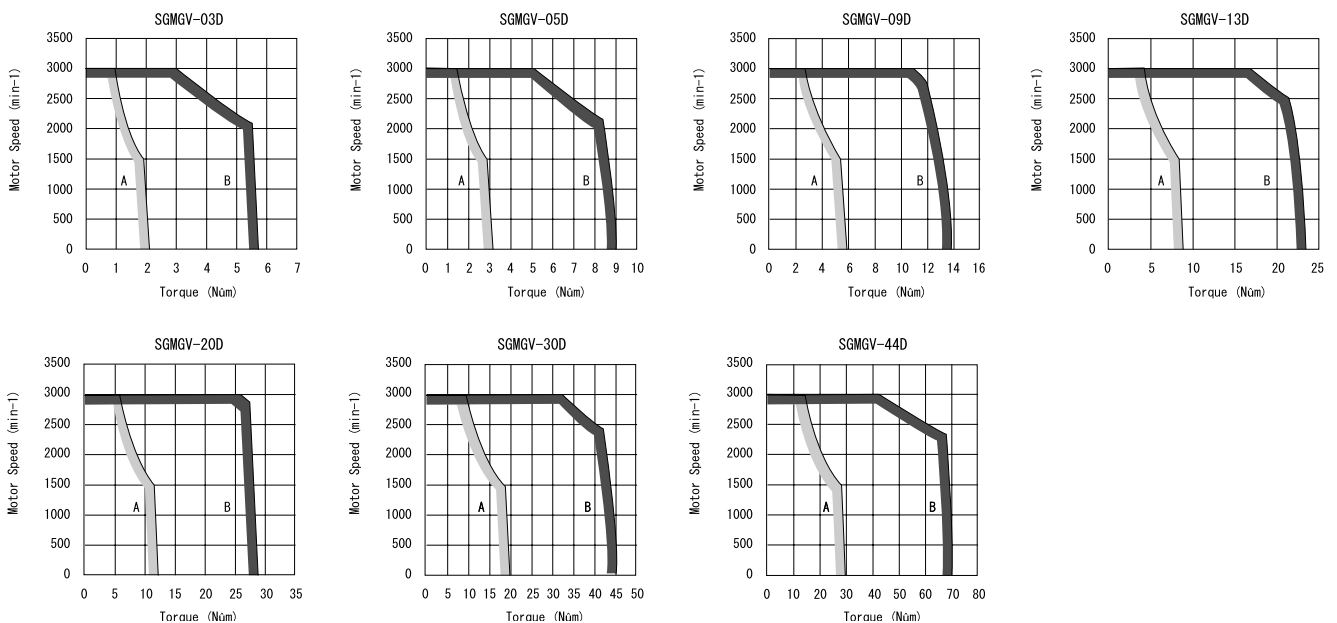

Type SGMSV, 400 V

Ratings and specifications

Applied voltage		400 V							
Servo motor model SGMSV-□		10D□	15D□	20D□	25D□	30D□	40D□	50D□	
Rated output ¹	kW	1.0	1.5	2.0	2.5	3.0	4.0	5.0	
Rated torque ^{1,2}	N·m	3.18	4.9	6.36	7.96	9.8	12.6	15.8	
Instantaneous peak torque ¹	N·m	9.54	14.7	19.1	23.9	29.4	37.8	47.6	
Rated current ¹	A (rms)	2.8	4.7	6.1	7.4	8.9	12.5	13.8	
Instantaneous max. current ¹	A (rms)	8.5	14	19.5	22.3	28	38	42	
Rated speed ¹	min ⁻¹	3000							
Max. speed ¹	min ⁻¹	6000	5000						
Torque constant	N·m/A (rms)	1.27	1.15	1.12	1.15	1.16	1.06	1.21	
Rotor moment of inertia (JM)	kg·m ² ×10 ⁻⁴ (without brake)	1.74	2.0	2.47	3.19	7.0	9.60	12.3	
	kg·m ² ×10 ⁻⁴ (with brake)	1.99	2.25	2.72	3.44	9.2	11.8	14.5	
Allowable load moment of inertia (JL)	Multiple of (JM)	5							
Rated power rate ¹	kW/s	57.9	97.2	127	199	137	165	203	
Rated angular acceleration ¹	rad/s ²	18300	24500	25700	25000	14000	13100	12800	
Encoder	Standard	Incremental encoder (20 bits)							
	Option	Absolute encoder (20 bits)							
Allowable radial load	N	686				980	1176		
Allowable thrust load	N	196				392			
Approx. mass	Kg (without brake)	4.6	5.1	5.8	7.0	11	14	17	
	Kg (with brake)	5.5	6	6.8	8.7	13	16	19	
Basic specifications	Time rating	Continuous							
	Thermal class	Class F							
	Usage/ storage temperature	0 to +40 °C/ -20 to 60°C without freezing							
	Usage/ storage humidity	20 to 80% RH (non-condensing)							
	Vibration class	15 µm or below							
	Insulation resistance	500 VDC, 10 MOhm min.							
	Withstand voltage	1500 VAC for one minute							
	Enclosure	Totally-enclosed, self-cooled, IP67 (excluding shaft opening)							
	Vibration resistance	Vibration acceleration xx.x m/s ²							
	Altitude	1000 m or less above sea level							
Mounting	Flange-mounted								

Note: *1. These items and torque/speed characteristics quoted in combination with an SGD V servo drive are at an armature winding temperature of 20°C.
 *2. The rated torques listed here are the values for the continuous allowable torque value with an aluminium heatsink of the following dimensions attached (SGMSV-10/15/20/25: 300 mm x 300 mm x 12 mm, SGMSV-30/40/50: 400 mm x 400 mm x 20 mm).

Torque-speed characteristics

A : Continuous Duty Zone B : Intermittent Duty Zone

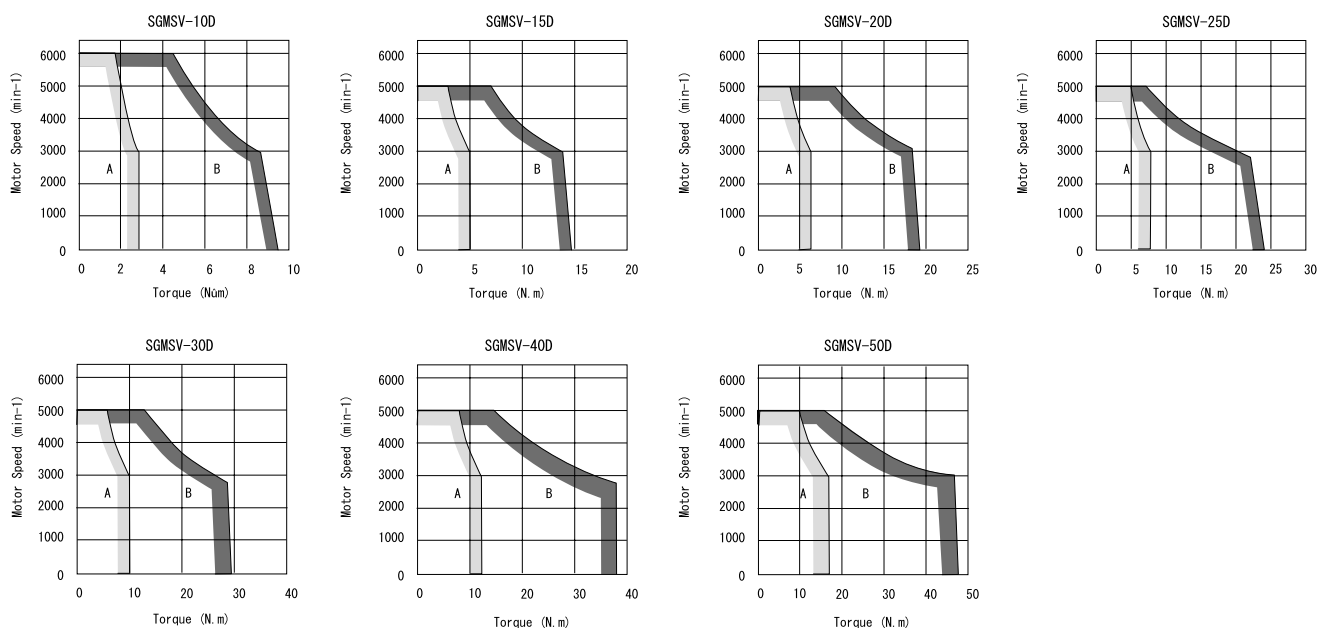

Type SGMAV (230 V, 50 - 150 W)

Dimensions (mm)	Without brake		With brake		LM	Shaft End Dimensions					Approx. Mass (Kg)	
	L	LL	L	LL		Tap x Depth	QK	U	W	T	Without brake	With brake
SGMAV-A5A□A6□-OY	95.5	70.5	140.5	115.5	38.5	M3x6L	14	1.8	3	3	0.3	0.6
SGMAV-01A□A6□-OY	107.5	82.5	152.5	127.5	50.5						0.4	0.7
SGMAV-C2A□A6□-OY	119.5	94.5	164.5	139.5	62.5						0.5	0.8

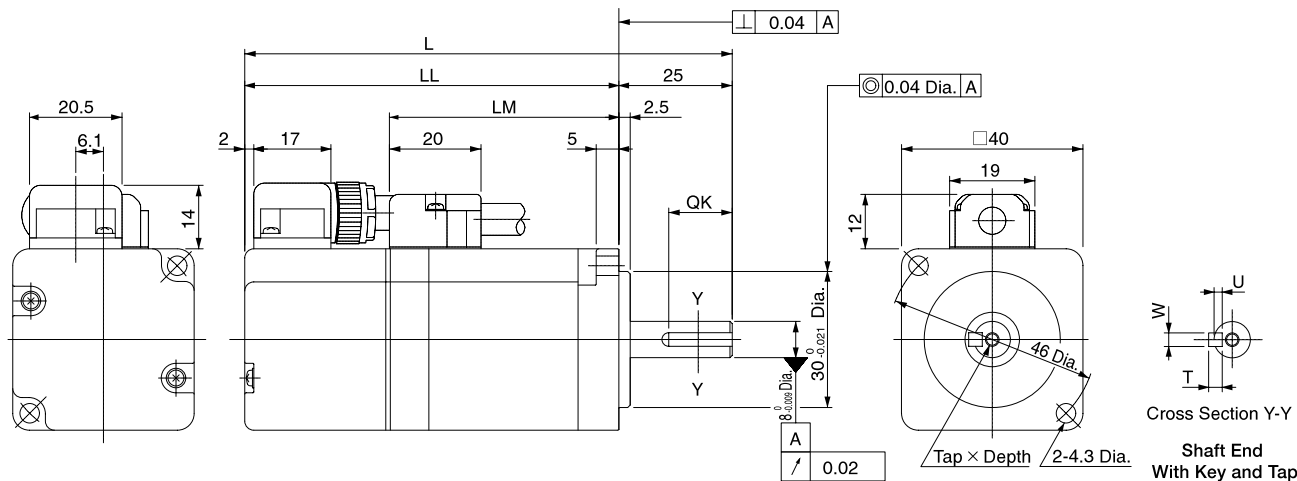

Type SGMAV (230 V, 200 - 750 W)

Dimensions (mm)	Without brake		With brake		LM	Flange Face Dimensions						Shaft End Dimensions					MD	MW	MH	Approx. Mass (Kg)			
	L	LL	L	LL		LR	LE	LG	LC	LA	LB	LZ	S	Tap x Depth	QK	U				W	T	Without brake	With brake
SGMAV-02A□A6□-OY	110	80	150	120	51	30	3	6	60	70	50 ⁰	5.5	14 ⁰	M5x8L	20	3	5	5	8.5	21	13	0.9	1.5
SGMAV-04A□A6□-OY	128.5	98.5	168.5	138.5	69.5						-0.025		-0.011		14							1.2	1.9
SGMAV-06A□A6□-OY	154.5	124.5	200.5	170.5	95.5																	1.7	2.4
SGMAV-08A□A6□-OY	155	115	200	160	85	40		8	80	90	70 ⁰	7	19 ⁰	M6x10L	22	3.5	6	6	13.8	27	15	2.3	3.2
SGMAV-10A□A6□-OY	185	145	235	195	115						-0.030		-0.013									3.6	4.6

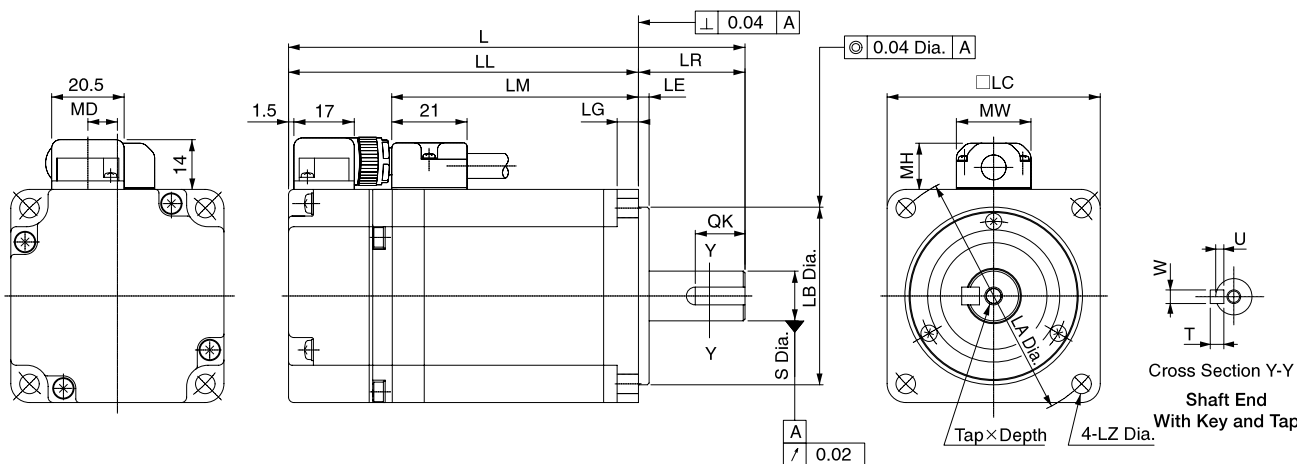

Type SGMEV (230/400 V, 100 - 1500 W)

Dimensions (mm)	Without brake		With brake		LM	Flange Face Dimensions						Shaft End Dimensions					Approx. Mass (Kg)		
	L	LL	L	LL		LA	LB	LC	LE	LG	LZ	S	QK	W	T	U	Tap x Depth	Without brake	With brake
SGMEV-01A□A6□-OY	87	62	116	91	25	70	50 ⁰ -0.030	60	3	6		8 ⁰ -0.011	14	3	3	1.8	M3 x 6L	0.7	0.9
SGMEV-02A□A6□-OY	97	67	128.5	98.5	30	90	70 ⁰ -0.030	80		8	7	14 ⁰ -0.011	16	5	5	3	M5 x 8L	1.4	1.9
SGMEV-02D□A6□-OY																		2.1	2.6
SGMEV-04A□A6□-OY																		2.1	2.6
SGMEV-04D□A6□-OY	117	87	148.5	118.5															
SGMEV-08A□A6□-OY	126.5	86.5	160	120	40	145	110 ⁰ -0.035	120	3.5	10	10	16 ⁰ -0.011	22					4.2	4.7
SGMEV-08D□A6□-OY	154.5	114.5	188	148								19 ⁰ -0.013						6.6	8.1
SGMEV-15A□A6□-OY												6.6	8.1						
SGMEV-15D□A6□-OY												6.6	8.1						

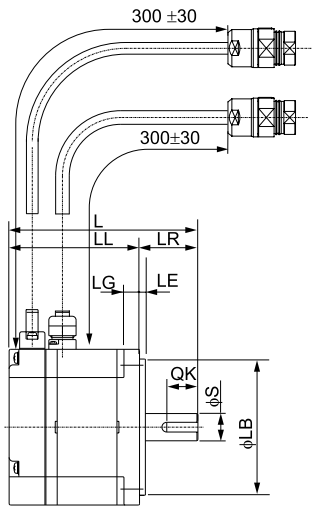

Models without Brake

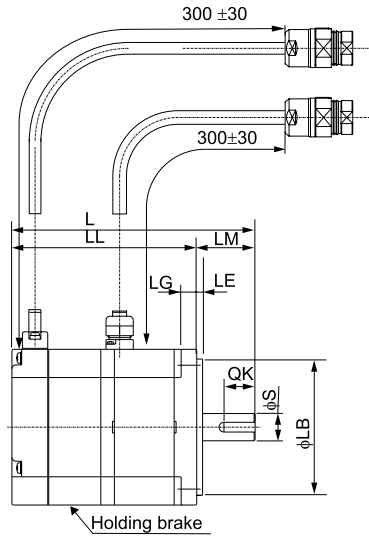

Models with Brake

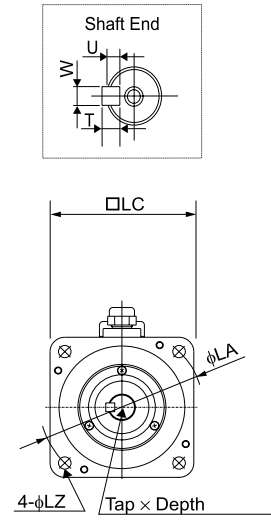

Type SGMEV (400 V, 300 - 650 W)

Dimensions (mm)	Without brake		With brake		LM	Flange Face Dimensions						Shaft End Dimensions					Approx. Mass (Kg)		
	L	LL	L	LL		LA	LB	LC	LE	LG	LZ	S	QK	W	T	U	Tap x Depth	Without brake	With brake
SGMEV-03D□A6□-OY	154.5	124.5	194	164	30	70	50 ⁰ -0.025	60	3	6	5.5	14 ⁰ -0.011	20	5	5	3	M5 x 8L	1.7	2.2
SGMEV-07D□A6□-OY	185	145	229.5	189.5	40	90	70 ⁰ -0.030	80	3	8	70	16 ⁰ -0.011	30					3.4	4.3

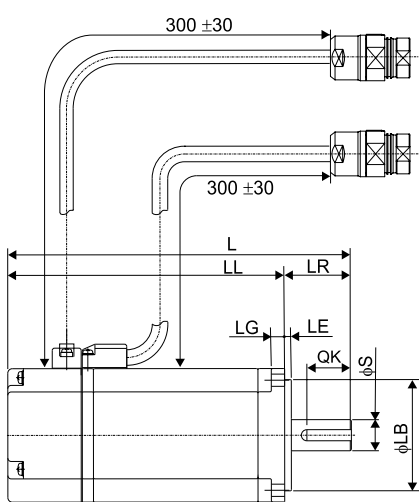

Models without Brake

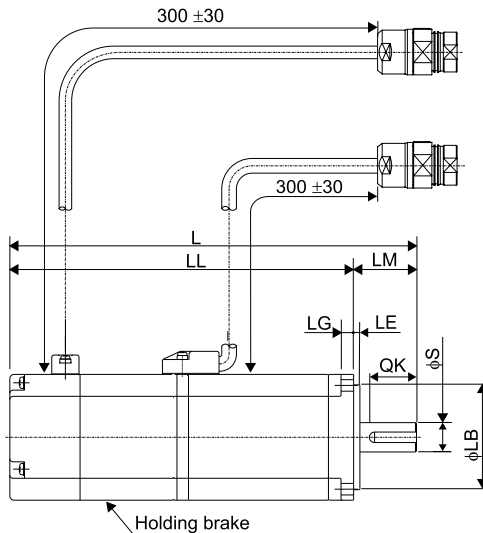

Models with Brake

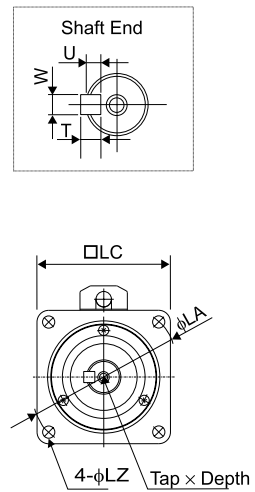

Type SGMGV (400 V, 300 - 450 W)

Dimensions (mm)	Without brake				With brake				LR	KB1	Shaft End Dimensions							Approx. Mass (Kg)	
	L	LL	LM	KB2	L	LL	LM	KB2			S	Q	QK	W	T	U	Tap x Depth	Without brake	With brake
SGMGV-03D□A6□-OY	163	126	90	114	196	159	123	147	37	75	14 ⁰ _{-0.011}	25	15	5	5	3	M4 x 10L	2.6	4.5
SGMGV-05D□A6□-OY	179	139	103	127	212	172	136	160	40	88	14 ⁰ _{-0.011}	30	20				M4 x 12L	3.2	5.0

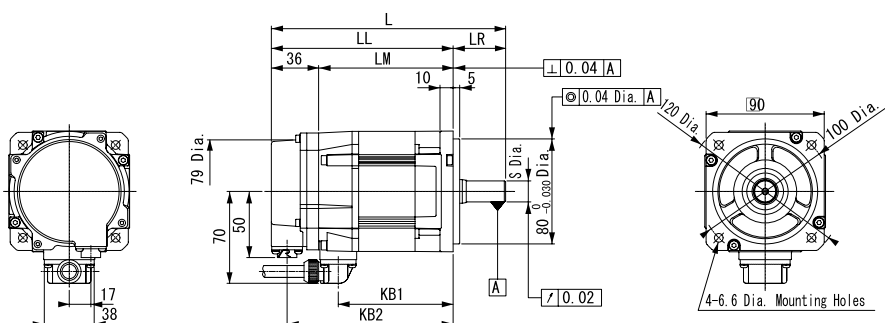

Models without brake

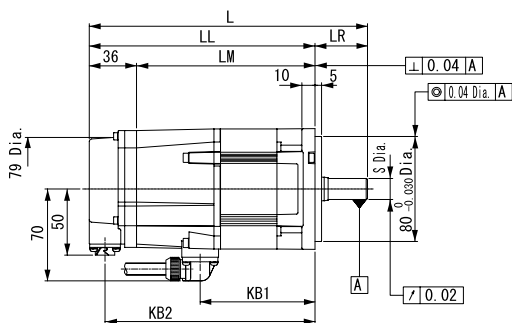

Models with brake

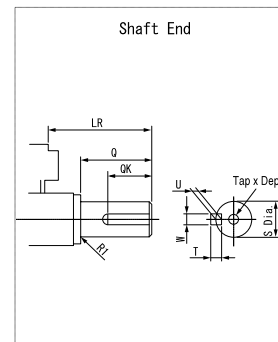

Type SGMGV (400 V, 850 W- 4.4 kW)

Dimensions (mm)	Without brake				With brake				LR	KB1	KL1	Flange Face Dimensions						Shaft End Dimensions						Approx. Mass (Kg)					
	Model	L	LL	LM	KB 2	L	LL	LM				KB2	KB 3	KL 3	LA	LB	LC	LE	LG	LH	LZ	S	Q	QK	W	T	U	Tap x Depth	Without brake
SGMGV-09D□A6□-OY	195	137	101	125	231	173	137	161	115	80	58	83	104	145	110 ⁰ -0.035	130	6	12	165	9	19 ⁰ -0.013	40	25	5	5	3	M5 x 12L	5.5	7.5
SGMGV-13D□A6□-OY	211	153	117	141	247	189	153	177	131			99											6	6	3.5		7.1	9.0	
SGMGV-20D□A6□-OY	229	171	135	159	265	207	171	195	149			117											8	7	4		8.6	11.0	
SGMGV-30D□A6□-OY	239	160	124	148	287	208	172	196	148	110	79	108	134	200	114.3 ⁰ -0.025	180	3.2	18	230	13.5	35 ^{+0.01} 0	76	60	10	8	5	M12 x 25L	13.4	19.5
SGMGV-44D□A6□-OY	263	184	148	172	311	232	196	220	172			132															17.5	23.5	

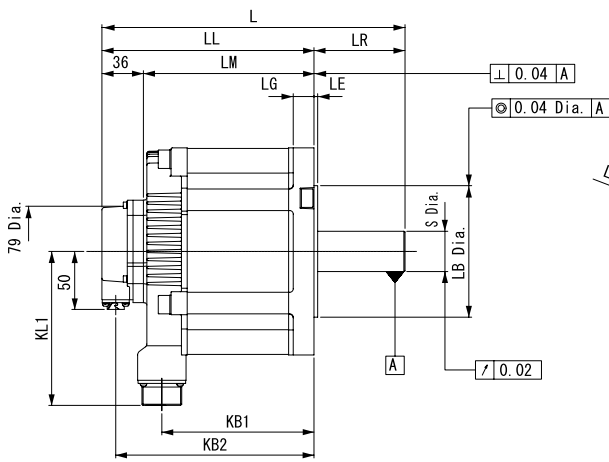

Models without brake

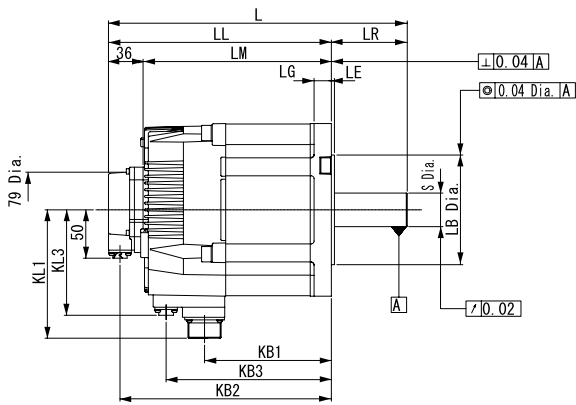

Models with brake

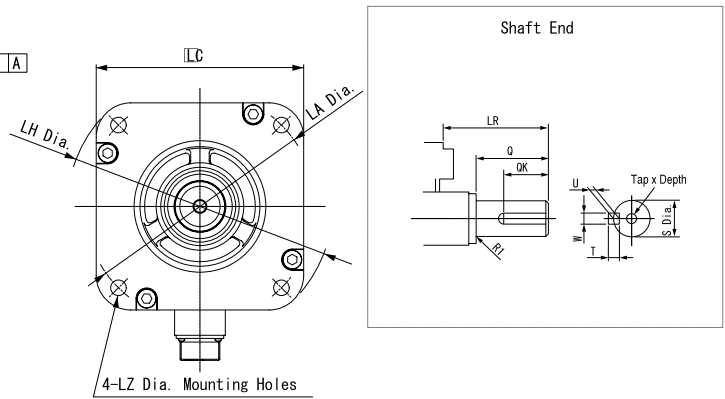

Type SGMSV (400 V, 1 - 5 kW)

Dimensions (mm)	Without brake					With brake							KB1	KL1	Flange Face Dimensions								Shaft End Dimensions						Approx. Mass (Kg)			
	Model	L	LL	LM	LR	KB2	L	LL	LM	LR	KB2	KB3			KL2	LA	LB	LC	LE	LF	LG	LH	LZ	S	Q	QK	W	T	U	Tap x Depth	With-out brake	With brake
		95 ⁰ -0.035	100	3	3	10	130	7	24 ⁰ -0.013	40	32	8			7	4	M8 x 16L	4.1	5.5													
SGMSV-10D□A2□-OY	192	147	111	45	135	233	188	152	45	118	176	69	76	96	115	95 ⁰ -0.035	100	3	3	10	130	7	24 ⁰ -0.013	40	32	8	7	4	M8 x 16L	4.1	5.5	
SGMSV-15D□A2□-OY	211	153	117	58	141	243	198	162	45	128	186		99																	4.6	6	
SGMSV-20D□A2□-OY	229	171	135	58	159	259	214	178	45	144	202		117																5.4	6.8		
SGMSV-25D□A2□-OY	239	160	124	79	148	292	247	211	45	177	225		108																6.8	8.7		
SGMSV-30D□A2□-OY	259	196	160	63	184	295	232	196	63	176	220	81	124	114	145	110 ⁰ -0.035	130	6	6	12	165	9	28 ⁰ -0.013	55	50					10.5	13	
SGMSV-40D□A2□-OY	296	233	197	63	221	332	269	233	63	213	257		161																13.5	16		
SGMSV-50D□A2□-OY	336	273	237	63	261	372	309	273	63	253	297		201																16.5	19		

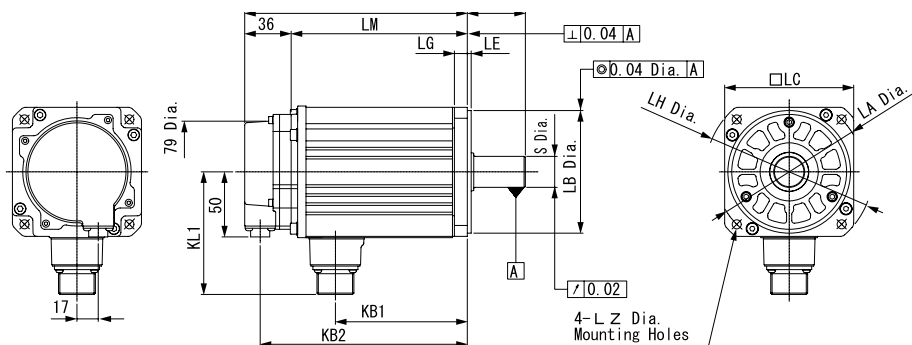

Models without brake

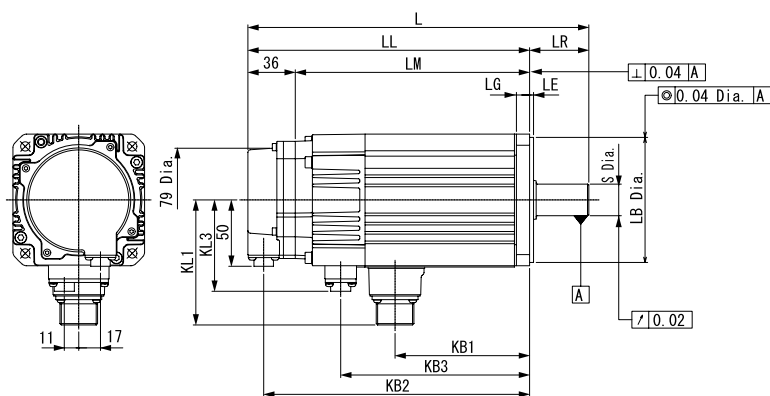
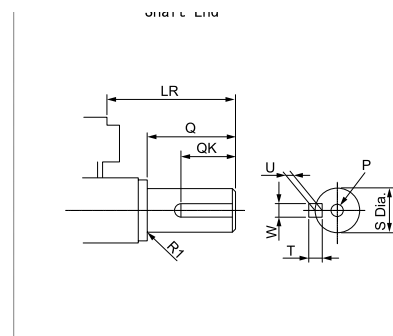

Models with brake

Dimensions

Sigma-5 Analog/Pulse Reference Servo Drive
SGDV-A5A0□A-OY to -02A0□A-OY (230 V, 50 to 200 W)

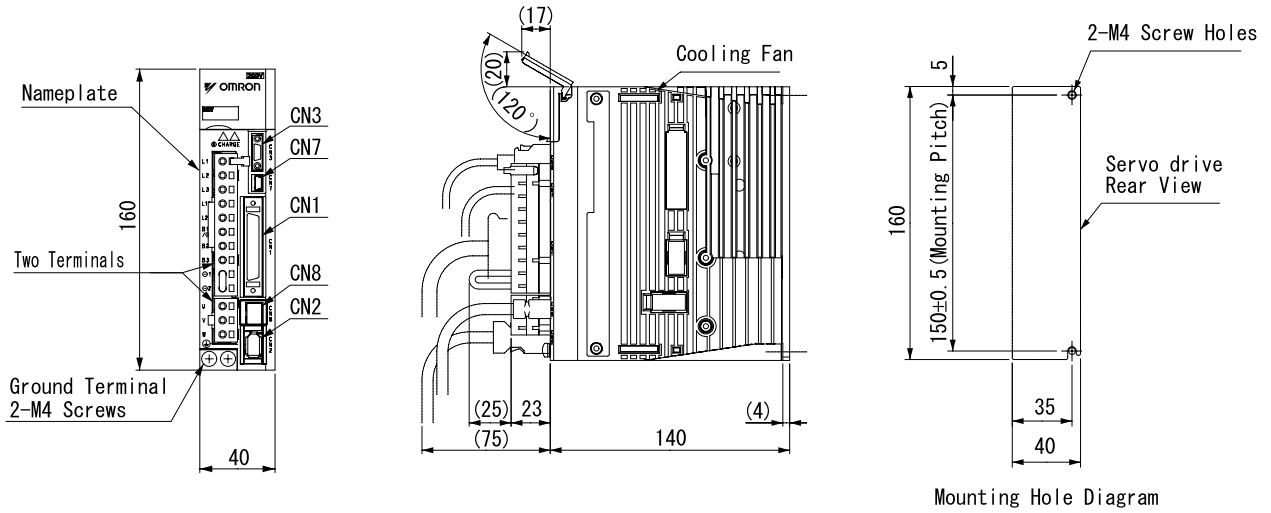

Mounting Hole Diagram

SGDV-04A0□A-OY (230 V, 400 W)

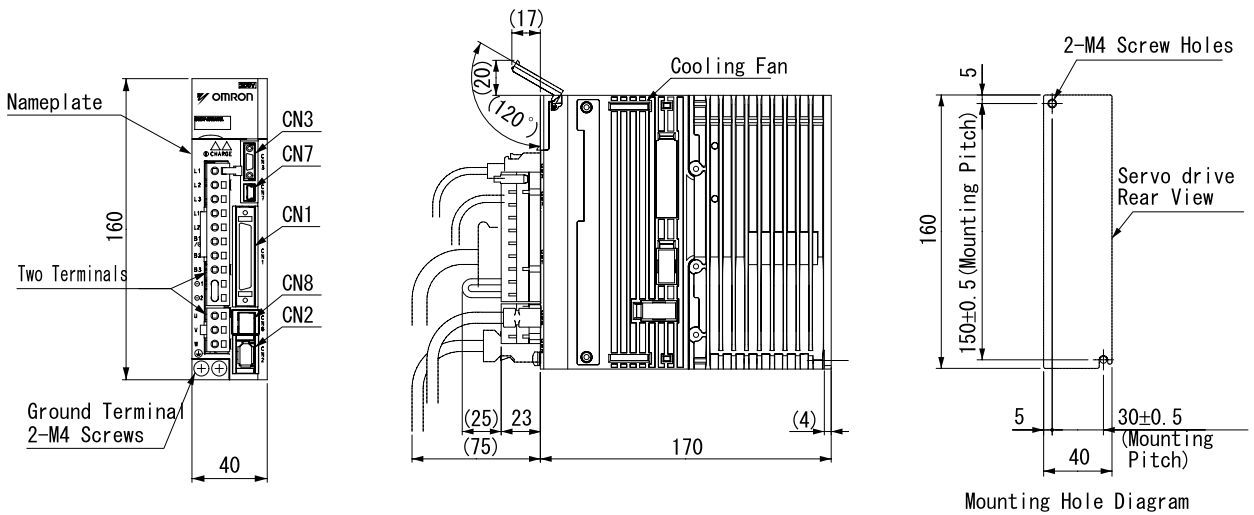

Mounting Hole Diagram

SGDV-08A0□A-OY (230 V, 750 W)

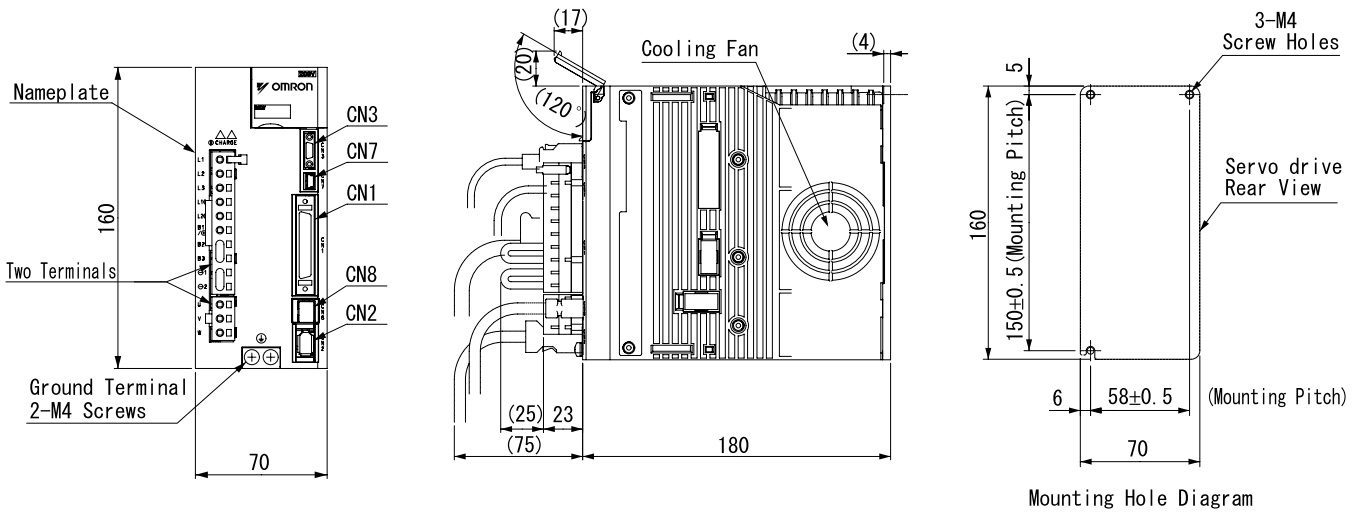

Mounting Hole Diagram

SGDV-15A0□A-OY (230 V, 1.5 kW)

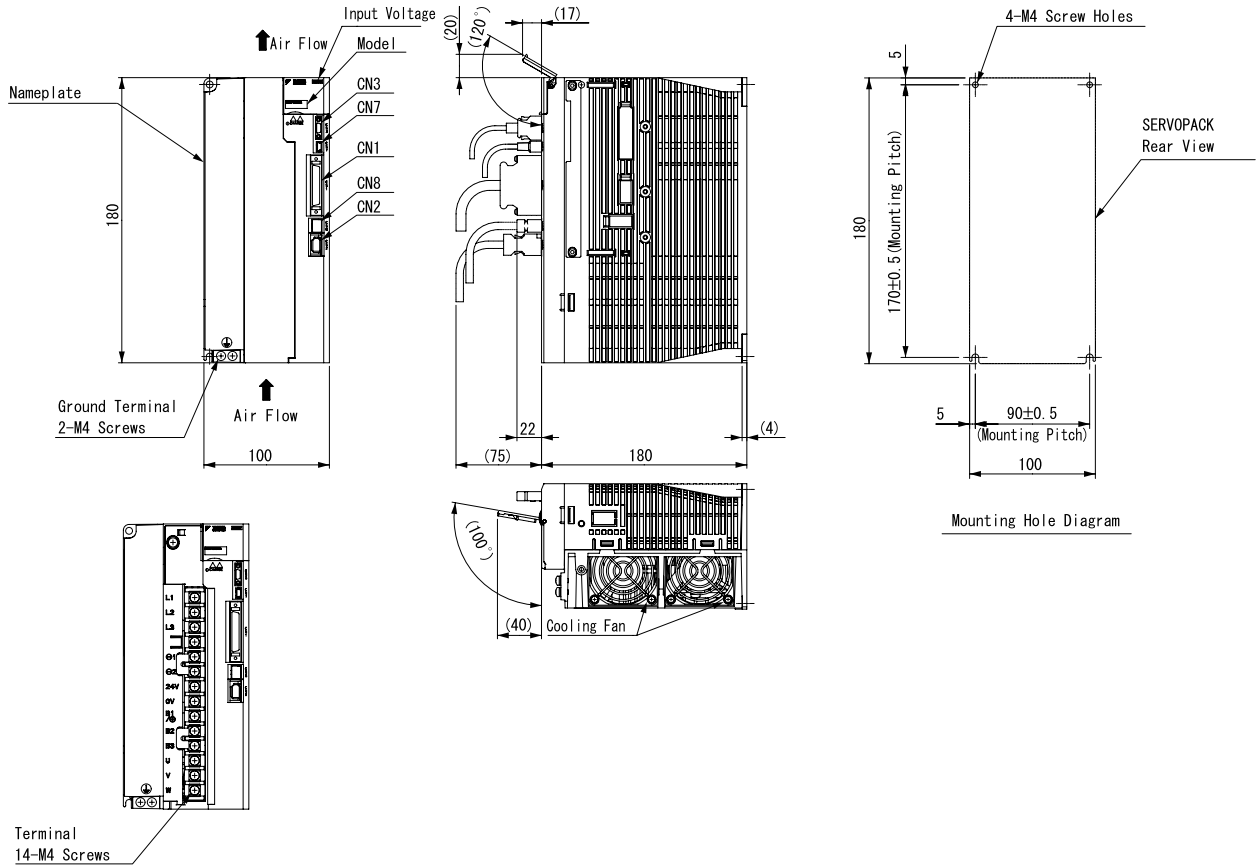

SGDV-05D0□A-OY to -15D0□A-OY (400 V, 0.5 to 1.5 kW)

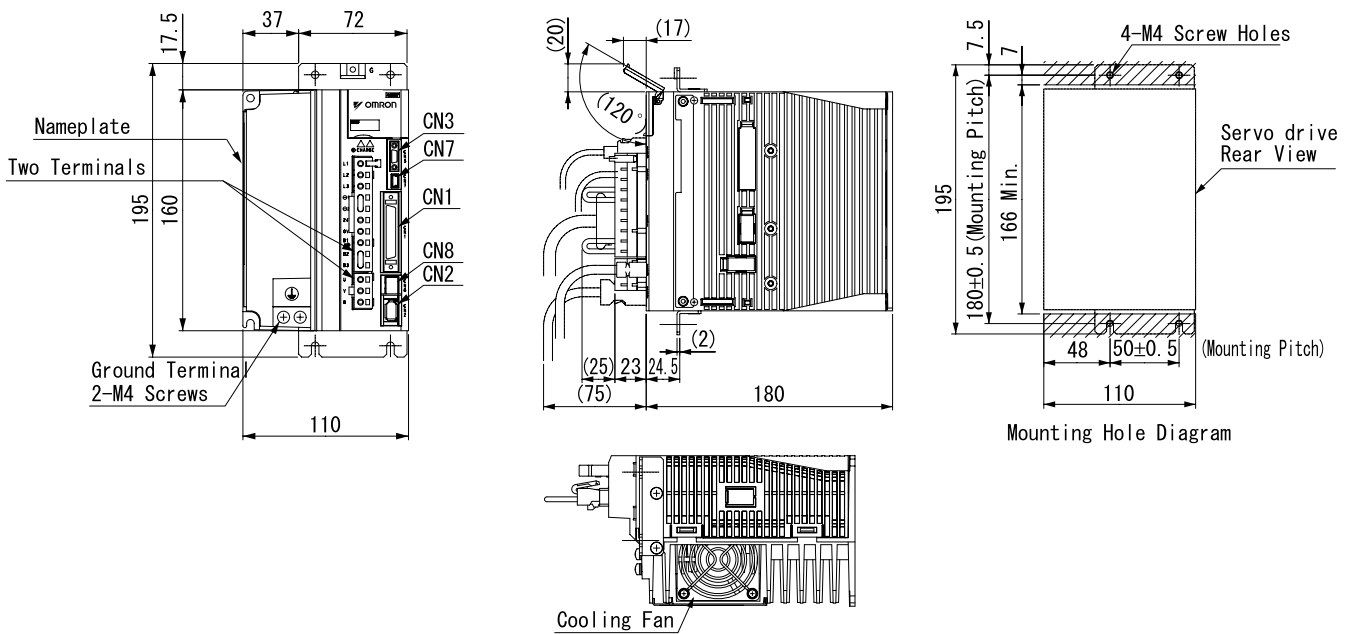

SGDV-20/30D0□A-OY (400 V, 2/3 kW)

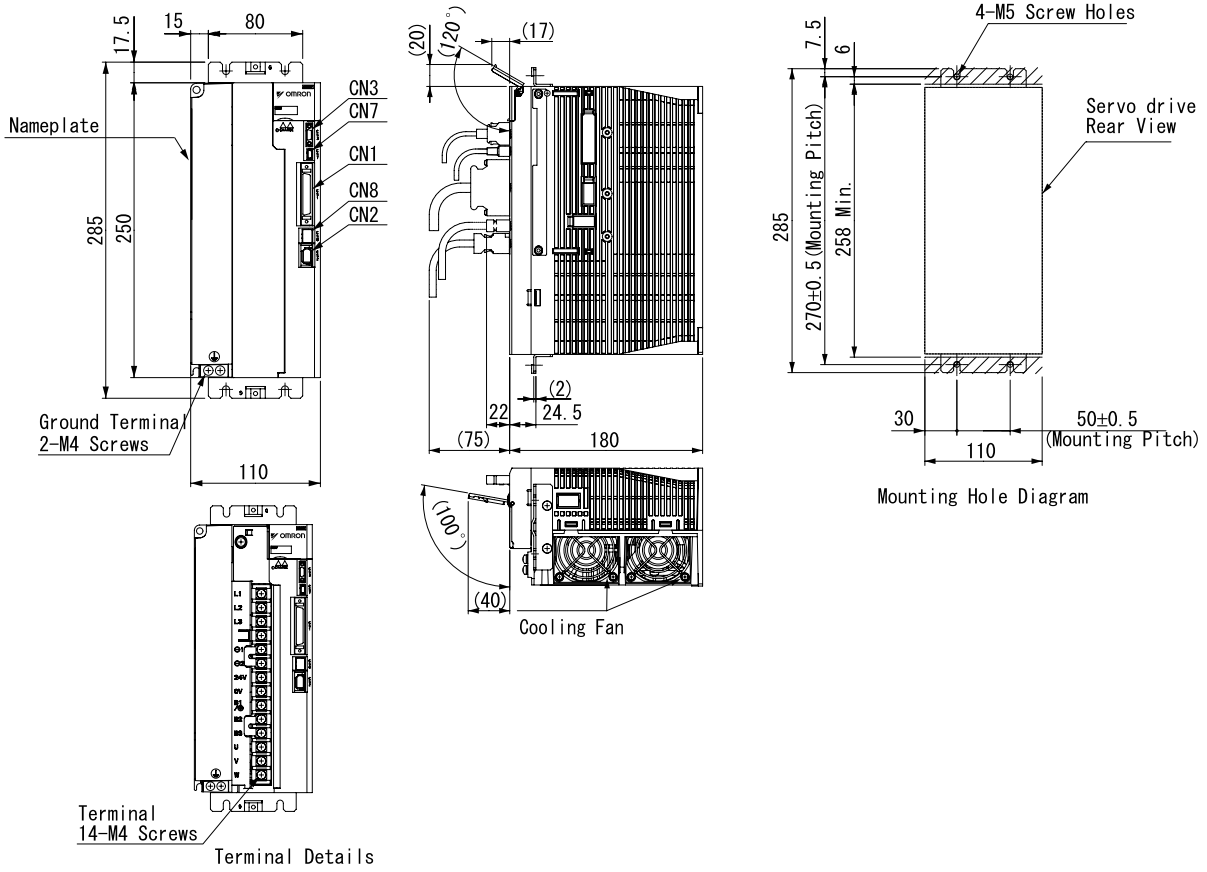

SGDV-50D0□A-OY (400 V, 5 kW)

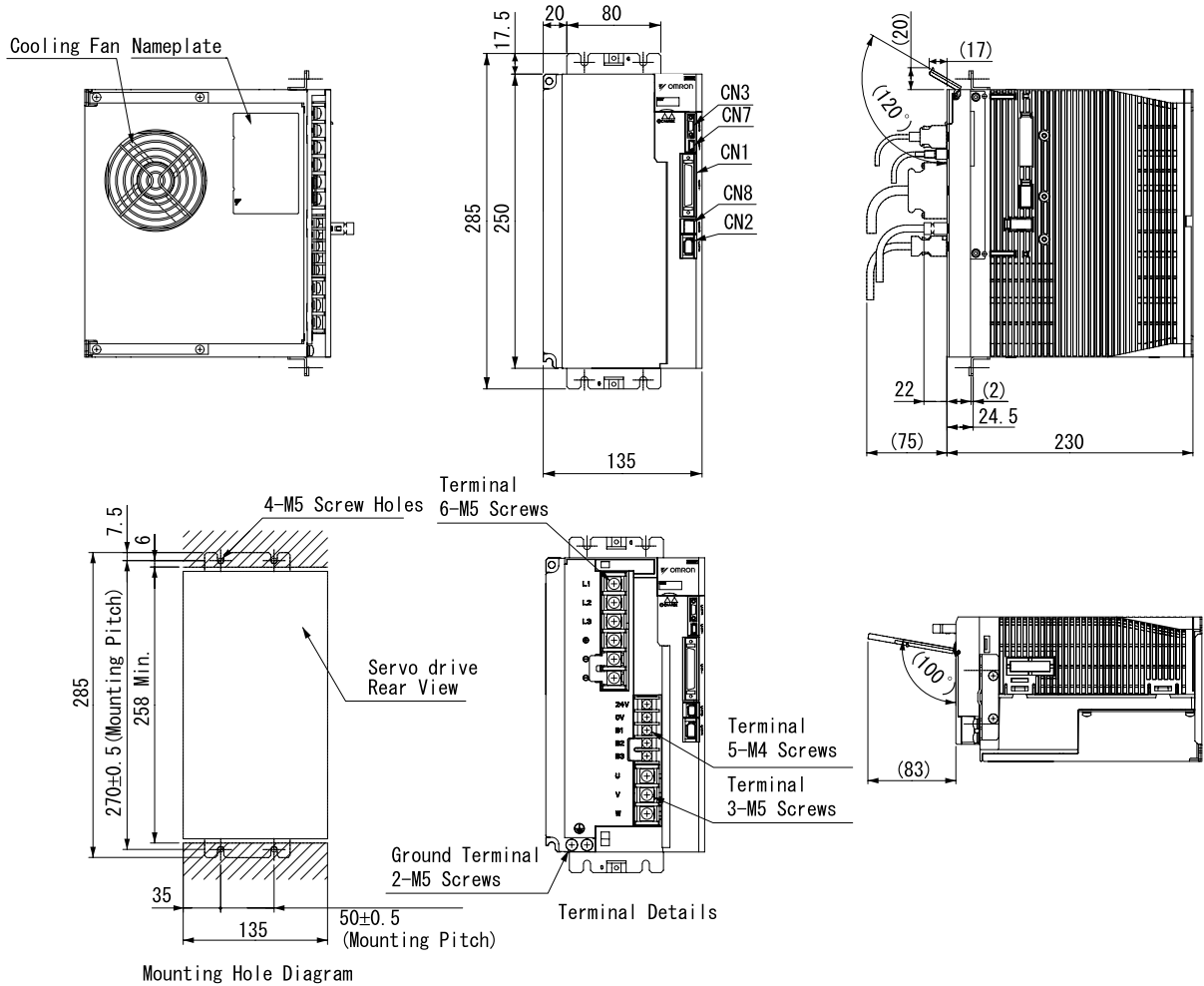

Sigma-5 MECHATROLINK-II Servo Drives

SGDV-A5A1□A-OY to -02A1□A-OY (230 V, 50 to 200 W)



Mounting Hole Diagram

SGDV-04A1□A-OY (230 V, 400 W)

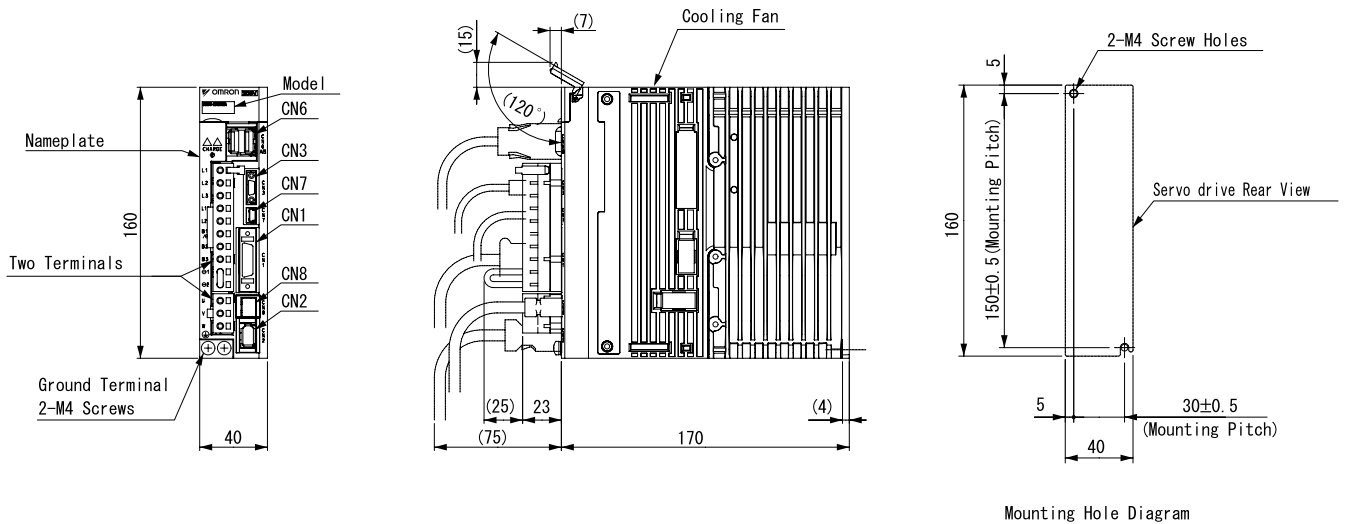

Mounting Hole Diagram

SGDV-08A1□A-OY (230 V, 750 W)

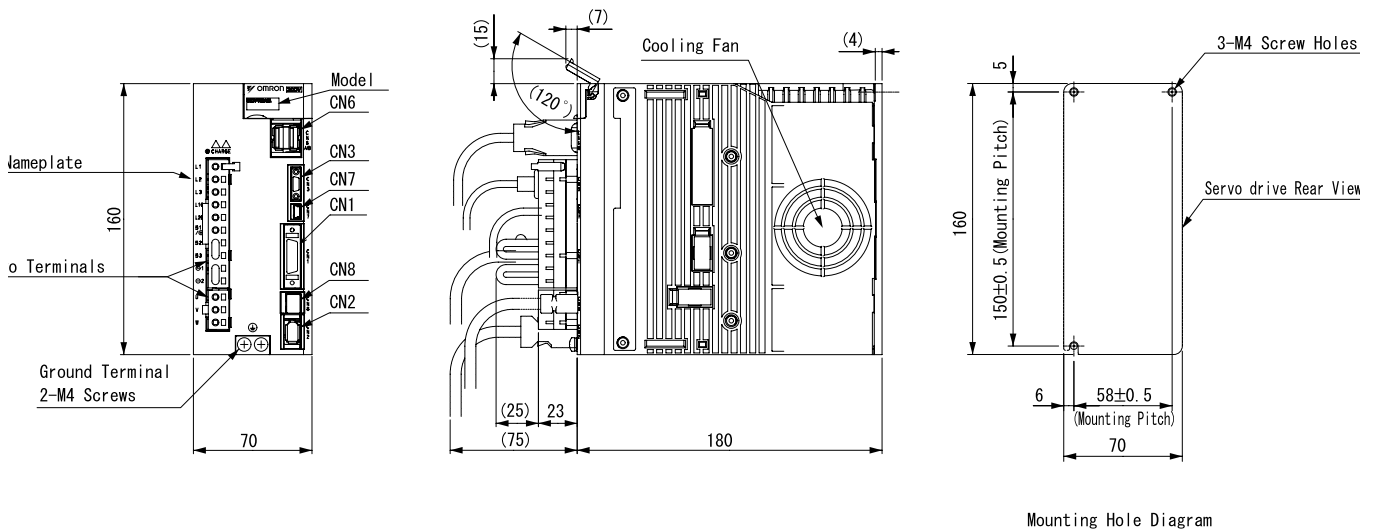

Mounting Hole Diagram

SGDV-15A1□A-OY (230 V, 1.5 kW)

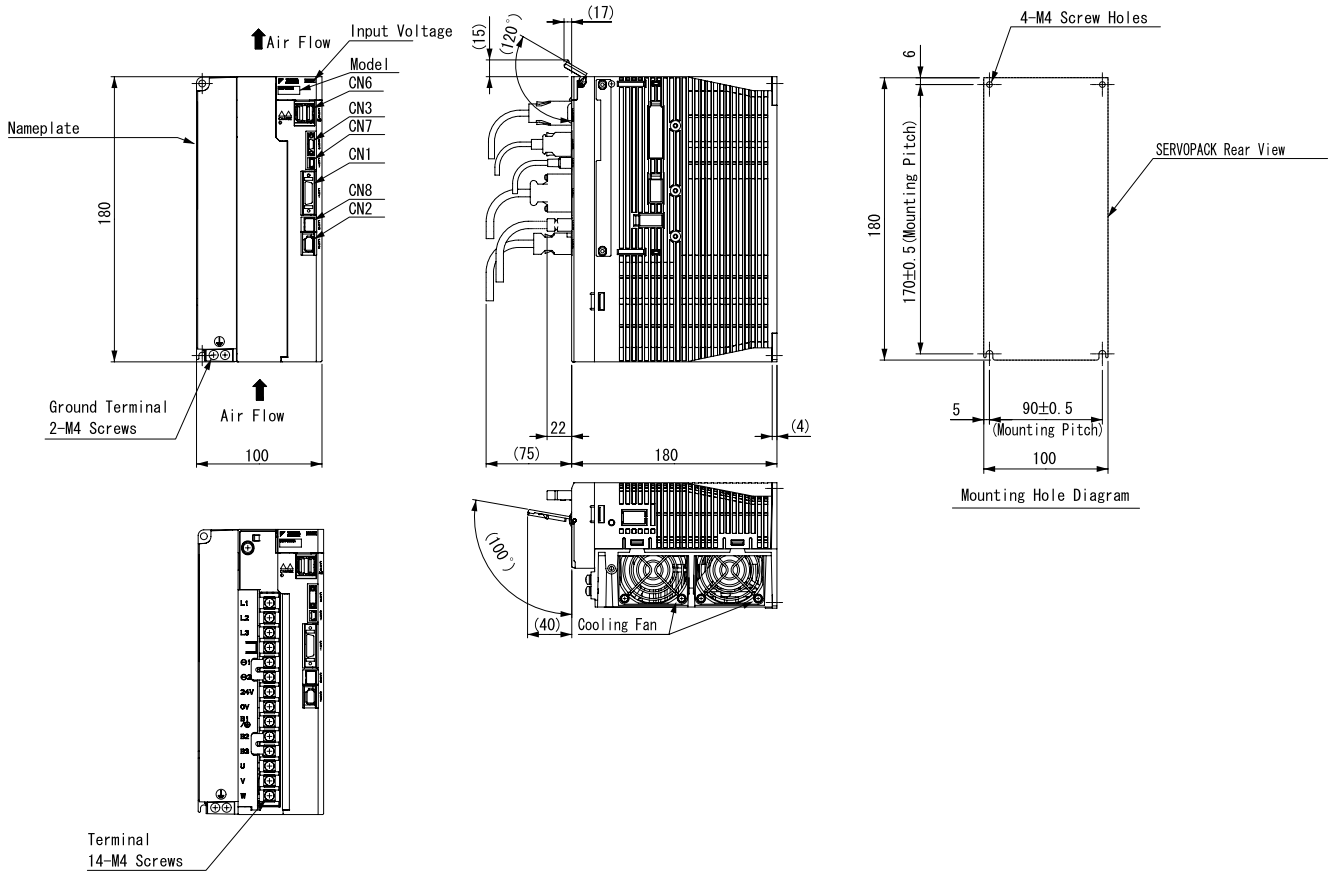

SGDV-05D1□A-OY to -15D1□A-OY (400 V, 0.5 to 1.5 kW)

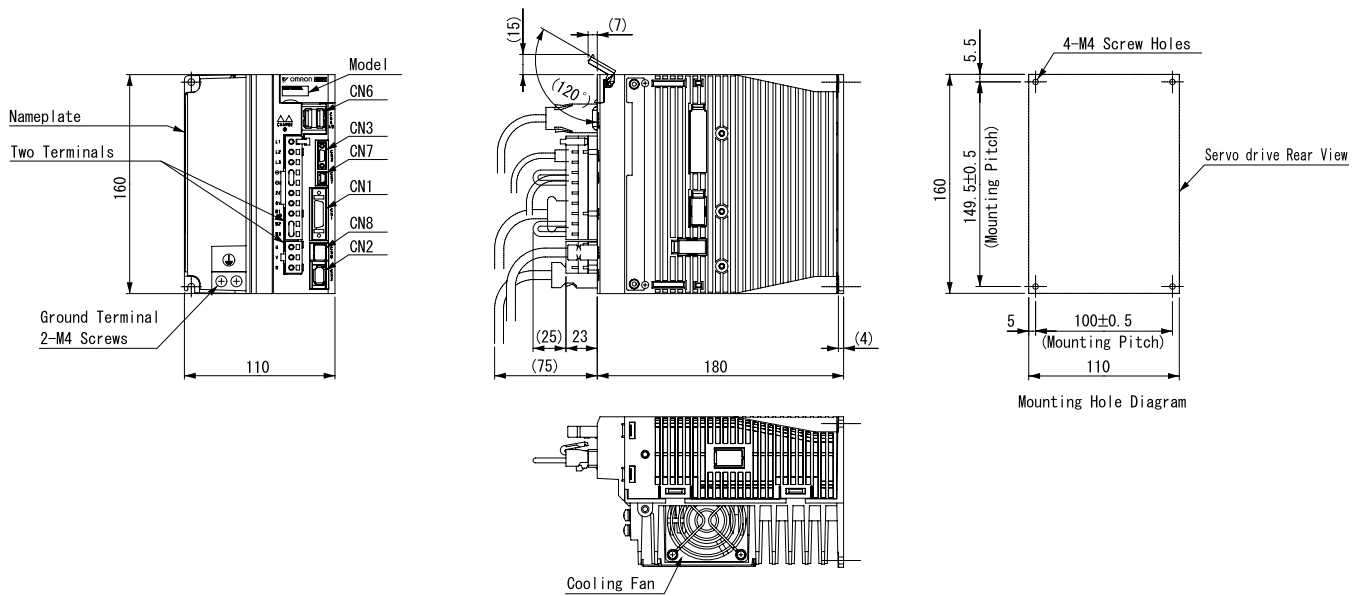

SGDV-20/30D1□A-OY (400 V, 2/3 kW)

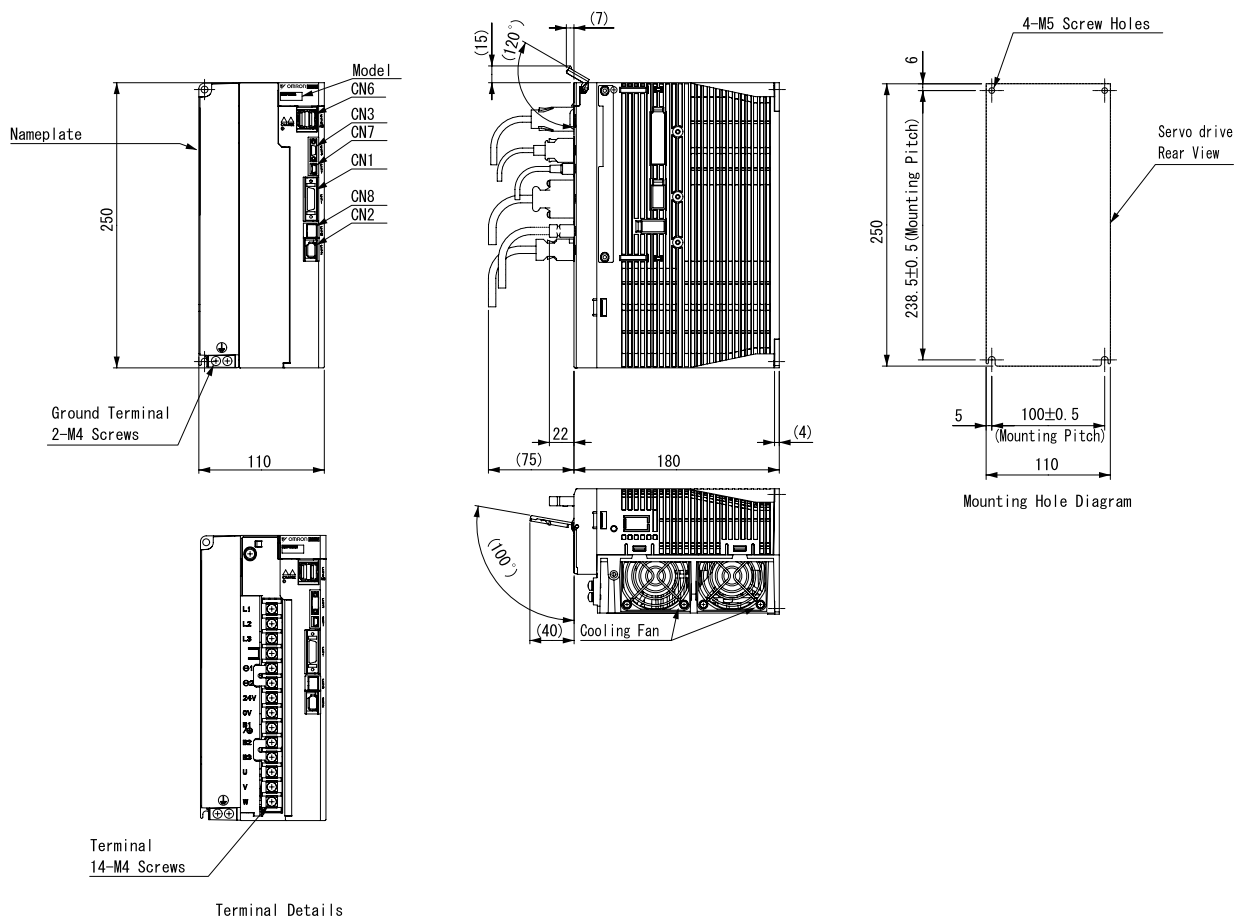

SGDV-50D1□A-OY (400 V, 5 kW)

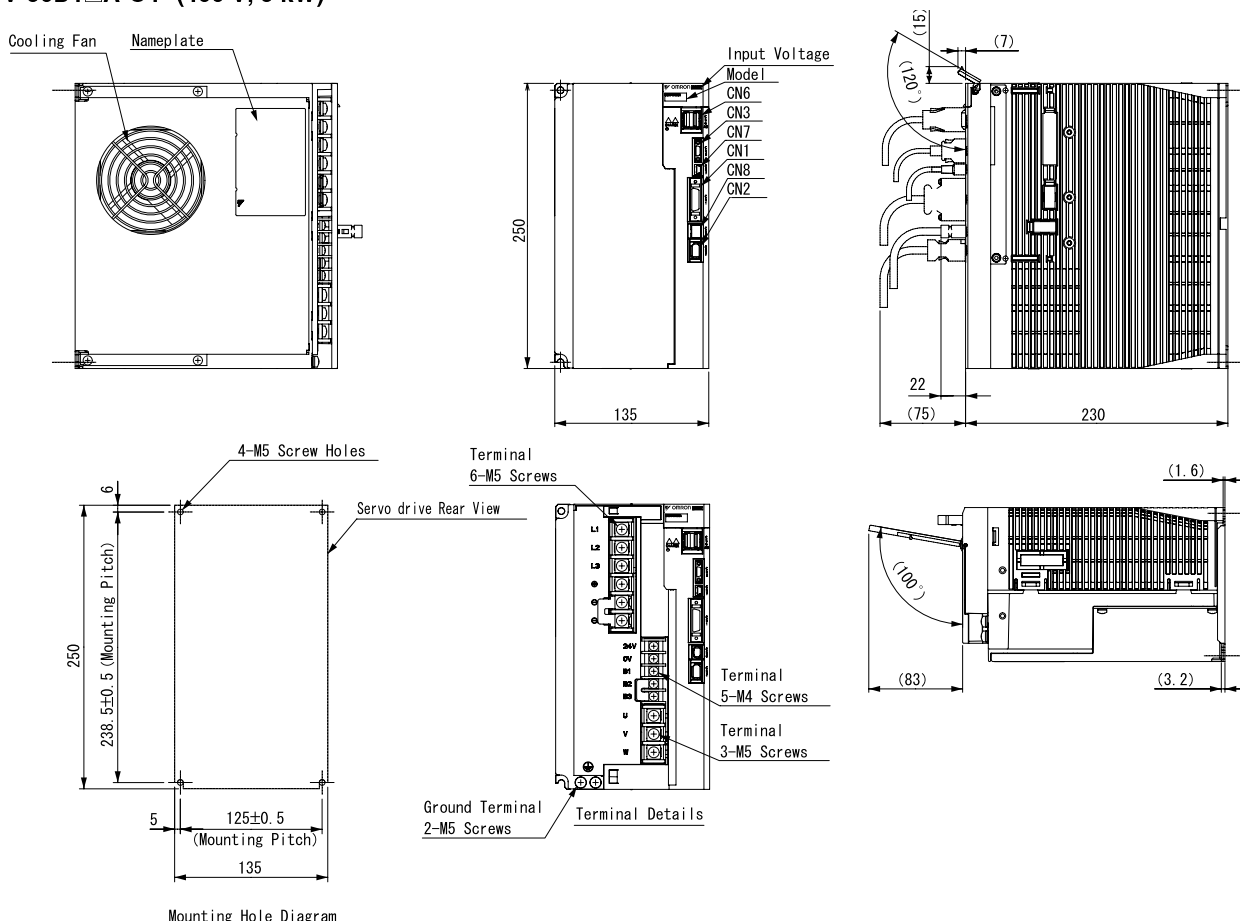

Ordering information

(Refer to servo drive chapter)

Drive options

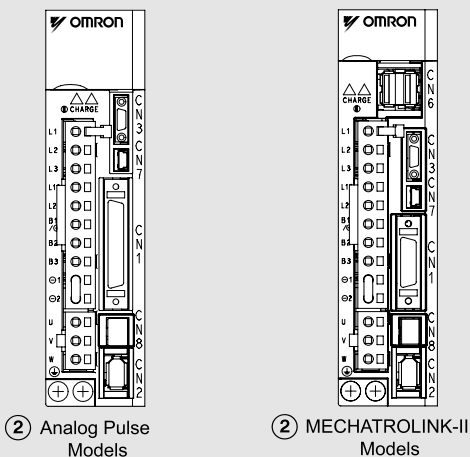

Power, encoder and brake cables

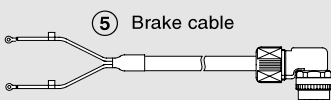
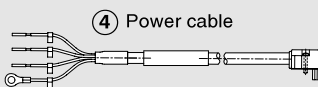
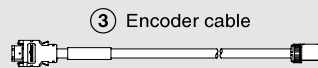

(a separate brake cable to use only for SGMGV and SGMSV servo motors from 850W)

Servo motors



1 SGMJV Servo Motor
3000 rpm (50-750 W)



1 SGMVA Servo Motor
3000 rpm (50W-1kW)



1 SGMEV Servo Motor
3000 rpm (100W-1.5kW)



1 SGMGV Servo Motor
1500 rpm (300W-4.4 kW)



1 SGMSV Servo Motor
3000 rpm (1-5kW)

Note: The symbols 1 2 3... show the recommended sequence to select the servo motor and cables

Servo motor

1 Select motor from families SGMJV, SGMVA, SGMEV, SGMGV, SGMSV using motor tables in next pages.

Servo drive

2 Refer to Sigma-5 servo drive chapter for detailed drive specifications and selection of drive accessories.

SGMJV - servo motors 3000 r/min (50 - 750 W)

Symbol	Specifications				Servo motor model	Compatible servo drives ⁽²⁾ Sigma-5	
	Voltage	Encoder and design		Rated torque			Capacity
	230 V	Incremental encoder (13 bit)	Without brake	0.159 Nm	50 W	SGMJV-A5AAA61-OY	SGDV-A5A□1A-OY
				0.318 Nm	100 W	SGMJV-01AAA61-OY	SGDV-01A□1A-OY
				0.637 Nm	200 W	SGMJV-02AAA61-OY	SGDV-02A□1A-OY
				1.27 Nm	400 W	SGMJV-04AAA61-OY	SGDV-04A□1A-OY
				2.39 Nm	750 W	SGMJV-08AAA61-OY	SGDV-08A□1A-OY
				2.39 Nm	750 W	SGMJV-08AAA6C-OY	SGDV-08A□1A-OY
			With brake	0.159 Nm	50 W	SGMJV-A5AAA6C-OY	SGDV-A5A□1A-OY
				0.318 Nm	100 W	SGMJV-01AAA6C-OY	SGDV-01A□1A-OY
				0.637 Nm	200 W	SGMJV-02AAA6C-OY	SGDV-02A□1A-OY
				1.27 Nm	400 W	SGMJV-04AAA6C-OY	SGDV-04A□1A-OY
				2.39 Nm	750 W	SGMJV-08AAA6C-OY	SGDV-08A□1A-OY
				2.39 Nm	750 W	SGMJV-08AAA6C-OY	SGDV-08A□1A-OY
		Incremental encoder (20 bit)	Without brake	0.159 Nm	50 W	SGMJV-A5ADA61-OY	SGDV-A5A□1A-OY
				0.318 Nm	100 W	SGMJV-01ADA61-OY	SGDV-01A□1A-OY
				0.637 Nm	200 W	SGMJV-02ADA61-OY	SGDV-02A□1A-OY
				1.27 Nm	400 W	SGMJV-04ADA61-OY	SGDV-04A□1A-OY
				2.39 Nm	750 W	SGMJV-08ADA61-OY	SGDV-08A□1A-OY
				2.39 Nm	750 W	SGMJV-08ADA6C-OY	SGDV-08A□1A-OY
			With brake	0.159 Nm	50 W	SGMJV-A5ADA6C-OY	SGDV-A5A□1A-OY
				0.318 Nm	100 W	SGMJV-01ADA6C-OY	SGDV-01A□1A-OY
				0.637 Nm	200 W	SGMJV-02ADA6C-OY	SGDV-02A□1A-OY
				1.27 Nm	400 W	SGMJV-04ADA6C-OY	SGDV-04A□1A-OY
				2.39 Nm	750 W	SGMJV-08ADA6C-OY	SGDV-08A□1A-OY
				2.39 Nm	750 W	SGMJV-08ADA6C-OY	SGDV-08A□1A-OY
Absolute encoder (20 bit)	Without brake	0.159 Nm	50 W	SGMJV-A5A3A61-OY	SGDV-A5A□1A-OY		
		0.318 Nm	100 W	SGMJV-01A3A61-OY	SGDV-01A□1A-OY		
		0.637 Nm	200 W	SGMJV-02A3A61-OY	SGDV-02A□1A-OY		
		1.27 Nm	400 W	SGMJV-04A3A61-OY	SGDV-04A□1A-OY		
		2.39 Nm	750 W	SGMJV-08A3A61-OY	SGDV-08A□1A-OY		
		2.39 Nm	750 W	SGMJV-08A3A6C-OY	SGDV-08A□1A-OY		
	With brake	0.159 Nm	50 W	SGMJV-A5A3A6C-OY	SGDV-A5A□1A-OY		
		0.318 Nm	100 W	SGMJV-01A3A6C-OY	SGDV-01A□1A-OY		
		0.637 Nm	200 W	SGMJV-02A3A6C-OY	SGDV-02A□1A-OY		
		1.27 Nm	400 W	SGMJV-04A3A6C-OY	SGDV-04A□1A-OY		
		2.39 Nm	750 W	SGMJV-08A3A6C-OY	SGDV-08A□1A-OY		
		2.39 Nm	750 W	SGMJV-08A3A6C-OY	SGDV-08A□1A-OY		

SGMAV - servo motors 3000 r/min (50 - 750 W)

Symbol	Specifications				Servo motor model	Compatible servo drives ⁽²⁾ Sigma-5		
	Voltage	Encoder and design		Rated torque			Capacity	
	230 V	Incremental encoder (20 bit)	Without brake	0.159 Nm	50 W	SGMAV-A5ADA61-OY	SGDV-A5A□1A-OY	
				0.318 Nm	100 W	SGMAV-01ADA61-OY	SGDV-01A□1A-OY	
				0.477 Nm	150 W	SGMAV-C2ADA61-OY	SGDV-02A□1A-OY	
				0.637 Nm	200 W	SGMAV-02ADA61-OY	SGDV-02A□1A-OY	
				1.27 Nm	400 W	SGMAV-04ADA61-OY	SGDV-04A□1A-OY	
				1.75 Nm	550 W	SGMAV-06ADA61-OY	SGDV-08A□1A-OY	
				2.39 Nm	750 W	SGMAV-08ADA61-OY	SGDV-08A□1A-OY	
				3.18 Nm	1 kW	SGMAV-10ADA61-OY	SGDV-15A□1A-OY-008000	
				0.159 Nm	50 W	SGMAV-A5ADA6C-OY	SGDV-A5A□1A-OY	
				0.318 Nm	100 W	SGMAV-01ADA6C-OY	SGDV-01A□1A-OY	
				0.477 Nm	150 W	SGMAV-C2ADA6C-OY	SGDV-02A□1A-OY	
				0.637 Nm	200 W	SGMAV-02ADA6C-OY	SGDV-02A□1A-OY	
			1.27 Nm	400 W	SGMAV-04ADA6C-OY	SGDV-04A□1A-OY		
			1.75 Nm	550 W	SGMAV-06ADA6C-OY	SGDV-08A□1A-OY		
			2.39 Nm	750 W	SGMAV-08ADA6C-OY	SGDV-08A□1A-OY		
			3.18 Nm	1 kW	SGMAV-10ADA6C-OY	SGDV-15A□1A-OY-008000		
			Without brake	Without brake	0.159 Nm	50 W	SGMAV-A5A3A61-OY	SGDV-A5A□1A-OY
					0.318 Nm	100 W	SGMAV-01A3A61-OY	SGDV-01A□1A-OY
					0.477 Nm	150 W	SGMAV-C2A3A61-OY	SGDV-02A□1A-OY
					0.637 Nm	200 W	SGMAV-02A3A61-OY	SGDV-02A□1A-OY
					1.27 Nm	400 W	SGMAV-04A3A61-OY	SGDV-04A□1A-OY
					1.75 Nm	550 W	SGMAV-06A3A61-OY	SGDV-08A□1A-OY
				With brake	0.159 Nm	50 W	SGMAV-A5A3A6C-OY	SGDV-A5A□1A-OY
					0.318 Nm	100 W	SGMAV-01A3A6C-OY	SGDV-01A□1A-OY
		0.477 Nm			150 W	SGMAV-C2A3A6C-OY	SGDV-02A□1A-OY	
		0.637 Nm			200 W	SGMAV-02A3A6C-OY	SGDV-02A□1A-OY	
		1.27 Nm			400 W	SGMAV-04A3A6C-OY	SGDV-04A□1A-OY	
		1.75 Nm			550 W	SGMAV-06A3A6C-OY	SGDV-08A□1A-OY	
		With brake	Without brake	0.159 Nm	50 W	SGMAV-A5A3A6C-OY	SGDV-A5A□1A-OY	
				0.318 Nm	100 W	SGMAV-01A3A6C-OY	SGDV-01A□1A-OY	
				0.477 Nm	150 W	SGMAV-C2A3A6C-OY	SGDV-02A□1A-OY	
				0.637 Nm	200 W	SGMAV-02A3A6C-OY	SGDV-02A□1A-OY	
				1.27 Nm	400 W	SGMAV-04A3A6C-OY	SGDV-04A□1A-OY	
				1.75 Nm	550 W	SGMAV-06A3A6C-OY	SGDV-08A□1A-OY	
			With brake	0.159 Nm	50 W	SGMAV-A5A3A6C-OY	SGDV-A5A□1A-OY	
				0.318 Nm	100 W	SGMAV-01A3A6C-OY	SGDV-01A□1A-OY	
0.477 Nm	150 W			SGMAV-C2A3A6C-OY	SGDV-02A□1A-OY			
0.637 Nm	200 W			SGMAV-02A3A6C-OY	SGDV-02A□1A-OY			
1.27 Nm	400 W			SGMAV-04A3A6C-OY	SGDV-04A□1A-OY			
1.75 Nm	550 W			SGMAV-06A3A6C-OY	SGDV-08A□1A-OY			



SGMGV - servo motors 1500 r/min (300 W - 4.4 kW)

Symbol	Specifications				Servo motor model	Compatible servo drives ⁽²⁾		
	Voltage	Encoder and design		Rated torque			Capacity	
	400 V	Incremental encoder (20 bit)	Without brake	1.96 Nm	300 W	SGMGV-03DDA6F-OY	SGDV-05D□1A-OY	
				2.86 Nm	450 W	SGMGV-05DDA6F-OY	SGDV-05D□1A-OY	
				5.39 Nm	850 W	SGMGV-09DDA6F-OY	SGDV-10D□1A-OY	
				8.34 Nm	1.3 kW	SGMGV-13DDA6F-OY	SGDV-15D□1A-OY	
				11.5 Nm	1.8 kW	SGMGV-20DDA6F-OY	SGDV-20D□1A-OY	
				18.6 Nm	2.9 kW	SGMGV-30DDA6F-OY	SGDV-30D□1A-OY	
			28.4 Nm	4.4 kW	SGMGV-44DDA6F-OY	SGDV-50D□1A-OY		
			With brake	1.96 Nm	300 W	SGMGV-03DDA6H-OY	SGDV-05D□1A-OY	
				2.86 Nm	450 W	SGMGV-05DDA6H-OY	SGDV-05D□1A-OY	
				5.39 Nm	850 W	SGMGV-09DDA6H-OY	SGDV-10D□1A-OY	
				8.34 Nm	1.3 kW	SGMGV-13DDA6H-OY	SGDV-15D□1A-OY	
				11.5 Nm	1.8 kW	SGMGV-20DDA6H-OY	SGDV-20D□1A-OY	
		18.6 Nm		2.9 kW	SGMGV-30DDA6H-OY	SGDV-30D□1A-OY		
		Absolute encoder (20 bit)	Without brake	Straight shaft with key and tap	1.96 Nm	300 W	SGMGV-03D3A6F-OY	SGDV-05D□1A-OY
					2.86 Nm	450 W	SGMGV-05D3A6F-OY	SGDV-05D□1A-OY
					5.39 Nm	850 W	SGMGV-09D3A6F-OY	SGDV-10D□1A-OY
					8.34 Nm	1.3 kW	SGMGV-13D3A6F-OY	SGDV-15D□1A-OY
					11.5 Nm	1.8 kW	SGMGV-20D3A6F-OY	SGDV-20D□1A-OY
					18.6 Nm	2.9 kW	SGMGV-30D3A6F-OY	SGDV-30D□1A-OY
			28.4 Nm	4.4 kW	SGMGV-44D3A6F-OY	SGDV-50D□1A-OY		
			With brake	1.96 Nm	300 W	SGMGV-03D3A6H-OY	SGDV-05D□1A-OY	
				2.86 Nm	450 W	SGMGV-05D3A6H-OY	SGDV-05D□1A-OY	
				5.39 Nm	850 W	SGMGV-09D3A6H-OY	SGDV-10D□1A-OY	
				8.34 Nm	1.3 kW	SGMGV-13D3A6H-OY	SGDV-15D□1A-OY	
11.5 Nm	1.8 kW			SGMGV-20D3A6H-OY	SGDV-20D□1A-OY			
18.6 Nm	2.9 kW	SGMGV-30D3A6H-OY		SGDV-30D□1A-OY				
28.4 Nm	4.4 kW	SGMGV-44D3A6H-OY	SGDV-50D□1A-OY					

SGMSV - servo motors 6000 r/min (1 - 5 kW)

Symbol	Specifications				Servo motor model	Compatible servo drives ⁽²⁾		
	Voltage	Encoder and design		Rated torque			Capacity	
	400 V	Incremental encoder (20 bit)	Without brake	3.18 Nm	1 kW	SGMSV-10DDA6F-OY	SGDV-10D□1A-OY	
				4.9 Nm	1.5 kW	SGMSV-15DDA6F-OY	SGDV-15D□1A-OY	
				6.36 Nm	2 kW	SGMSV-20DDA6F-OY	SGDV-20D□1A-OY	
				7.96 Nm	2.5 kW	SGMSV-25DDA6F-OY	SGDV-30D□1A-OY	
				9.8 Nm	3 kW	SGMSV-30DDA6F-OY	SGDV-30D□1A-OY	
				12.6 Nm	4 kW	SGMSV-40DDA6F-OY	SGDV-50D□1A-OY	
			15.8 Nm	5 kW	SGMSV-50DDA6F-OY	SGDV-50D□1A-OY		
			With brake	3.18 Nm	1 kW	SGMSV-10DDA6H-OY	SGDV-10D□1A-OY	
				4.9 Nm	1.5 kW	SGMSV-15DDA6H-OY	SGDV-15D□1A-OY	
				6.36 Nm	2 kW	SGMSV-20DDA6H-OY	SGDV-20D□1A-OY	
				7.96 Nm	2.5 kW	SGMSV-25DDA6H-OY	SGDV-30D□1A-OY	
				9.8 Nm	3 kW	SGMSV-30DDA6H-OY	SGDV-30D□1A-OY	
		12.6 Nm		4 kW	SGMSV-40DDA6H-OY	SGDV-50D□1A-OY		
		15.8 Nm	5 kW	SGMSV-50DDA6H-OY	SGDV-50D□1A-OY			
		Absolute encoder (20 bit)	Without brake	Straight shaft with key and tap	3.18 Nm	1 kW	SGMSV-10D3A6F-OY	SGDV-10D□1A-OY
					4.9 Nm	1.5 kW	SGMSV-15D3A6F-OY	SGDV-15D□1A-OY
					6.36 Nm	2 kW	SGMSV-20D3A6F-OY	SGDV-20D□1A-OY
					7.96 Nm	2.5 kW	SGMSV-25D3A6F-OY	SGDV-30D□1A-OY
					9.8 Nm	3 kW	SGMSV-30D3A6F-OY	SGDV-30D□1A-OY
					12.6 Nm	4 kW	SGMSV-40D3A6F-OY	SGDV-50D□1A-OY
			15.8 Nm	5 kW	SGMSV-50D3A6F-OY	SGDV-50D□1A-OY		
			With brake	3.18 Nm	1 kW	SGMSV-10D3A6H-OY	SGDV-10D□1A-OY	
				4.9 Nm	1.5 kW	SGMSV-15D3A6H-OY	SGDV-15D□1A-OY	
				6.36 Nm	2 kW	SGMSV-20D3A6H-OY	SGDV-20D□1A-OY	
7.96 Nm	2.5 kW			SGMSV-25D3A6H-OY	SGDV-30D□1A-OY			
9.8 Nm	3 kW			SGMSV-30D3A6H-OY	SGDV-30D□1A-OY			
12.6 Nm	4 kW	SGMSV-40D3A6H-OY		SGDV-50D□1A-OY				
15.8 Nm	5 kW	SGMSV-50D3A6H-OY	SGDV-50D□1A-OY					

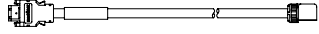
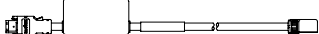
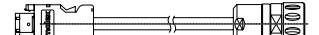
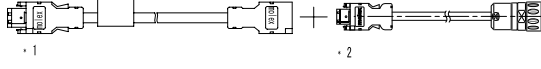
Encoder Cables for sigma-5 servo drive

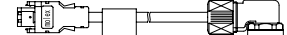
Symbol	Specifications	Model	Appearance	
③	Sigma-5 incremental encoder cable for SGMJV/AV Servo motors SGMJV-□□ADA□□-OY, SGMJV-□□AAA□□-OY, SGMAV-□□ADA□□-OY	3 m	JZSP-CSP21-03-E-G1	
		5 m	JZSP-CSP21-05-E-G1	
		10 m	JZSP-CSP21-10-E-G1	
		15 m	JZSP-CSP21-15-E-G1	
		20 m	JZSP-CSP21-20-E-G1	
	Sigma-5 absolute encoder cable (with a battery case) for SGMJV/AV Servo motors SGMJV-□□A3A□□-OY SGMAV-□□A3A□□-OY	3 m	JZSP-CSP25-03-G1	
		5 m	JZSP-CSP25-05-G1	
		10 m	JZSP-CSP25-10-G1	
		15 m	JZSP-CSP25-15-G1	
		20 m	JZSP-CSP25-20-G1	
	Sigma-5 incremental encoder cable for SGMEV Servo motors	3 m	R88A-CRWA003C-DE	
		5 m	R88A-CRWA005C-DE	
		10 m	R88A-CRWA010C-DE	
		15 m	R88A-CRWA015C-DE	
		20 m	R88A-CRWA020C-DE	
	Sigma-5 absolute encoder cable extension with a battery case for SGMEV Servo motors Note: *1 This cable is only an extension and must be used in conjunction with incremental encoder cable *2 R88A-CRWA0□□C-DE	0.3 m	JZSP-CSP12-E	
	Sigma-5 incremental encoder cable for SGMGV/SV Servo motors SGMGV-□□DDA□□-OY SGMSV-□□DDA□□-OY	3 m	JZSP-CVP12-03-E-G1	
		5 m	JZSP-CVP12-05-E-G1	
		10 m	JZSP-CVP12-10-E-G1	
		15 m	JZSP-CVP12-15-E-G1	
20 m		JZSP-CVP12-20-E-G1		
Sigma-5 absolute encoder cable (with a battery case) for SGMGV/SV Servo motors SGMGV-□□D3A□□-OY SGMSV-□□D3A□□-OY	3 m	JZSP-CVP27-03-G1		
	5 m	JZSP-CVP27-05-G1		
	10 m	JZSP-CVP27-10-G1		
	15 m	JZSP-CVP27-15-G1		
	20 m	JZSP-CVP27-20-G1		

Power cables

Symbol	Specifications	Model	Appearance	
④	For 200 V servo motors without brake SGMJV-(A5/01)A□A□1-OY SGMAV-(A5/01/C2)ADA□1-OY	3 m	JZSP-CSM21-03-E-G1	
		5 m	JZSP-CSM21-05-E-G1	
		10 m	JZSP-CSM21-10-E-G1	
		15 m	JZSP-CSM21-15-E-G1	
		20 m	JZSP-CSM21-20-E-G1	
	For 200 V servo motors with brake SGMJV-(A5/01)A□A□C-OY SGMAV-(A5/01/C2)A□A□C-OY	3 m	JZSP-CSM31-03-E-G1	
		5 m	JZSP-CSM31-05-E-G1	
		10 m	JZSP-CSM31-10-E-G1	
		15 m	JZSP-CSM31-15-E-G1	
		20 m	JZSP-CSM31-20-E-G1	
	For 200 V servo motors without brake SGMJV-(02/04)A□A□1-OY SGMAV-(02/04/06)A□A□1-OY	3 m	JZSP-CSM22-03-E-G1	
		5 m	JZSP-CSM22-05-E-G1	
		10 m	JZSP-CSM22-10-E-G1	
		20 m	JZSP-CSM22-20-E-G1	
	For 200 V servo motors with brake SGMJV-(02/04)A□A□C-OY SGMAV-(02/04/06)A□A□C-OY	3 m	JZSP-CSM32-03-E-G1	
		5 m	JZSP-CSM32-05-E-G1	
		10 m	JZSP-CSM32-10-E-G1	
		20 m	JZSP-CSM32-20-E-G1	
	For 200 V servo motors without brake SGMJV-08A□A□1-OY SGMAV-08A□A□1-OY SGMAV-10A□A□1-OY	3 m	JZSP-CSM23-03-E-G1	
		5 m	JZSP-CSM23-05-E-G1	
		10 m	JZSP-CSM23-10-E-G1	
		20 m	JZSP-CSM23-20-E-G1	
	For 200 V servo motors with brake SGMJV-08A□A□C-OY SGMAV-08A□A□C-OY SGMAV-10A□A□C-OY	3 m	JZSP-CSM33-03-E-G1	
		5 m	JZSP-CSM33-05-E-G1	
		10 m	JZSP-CSM33-10-E-G1	
		20 m	JZSP-CSM33-20-E-G1	
	For 200 V servo motors without brake SGMEV-(01/02/04/08)A□A□1-OY	3 m	R88A-CAWA003S-DE	
		5 m	R88A-CAWA005S-DE	
		10 m	R88A-CAWA010S-DE	
		15 m	R88A-CAWA015S-DE	
		20 m	R88A-CAWA020S-DE	
	For 200 V servo motors with brake SGMEV-(01/02/04/08)A□A□C-OY	3 m	R88A-CAWA003B-DE	
		5 m	R88A-CAWA005B-DE	
		10 m	R88A-CAWA010B-DE	
		20 m	R88A-CAWA020B-DE	
	For 200 V servo motors without brake SGMEV-15A□A□1-OY	3 m	R88A-CAWB003S-DE	
		5 m	R88A-CAWB005S-DE	
		10 m	R88A-CAWB010S-DE	
		15 m	R88A-CAWB015S-DE	
		20 m	R88A-CAWB020S-DE	
	For 200 V servo motors with brake SGMEV-15A□A□C-OY	3 m	R88A-CAWB003B-DE	
		5 m	R88A-CAWB005B-DE	
		10 m	R88A-CAWB010B-DE	
		20 m	R88A-CAWB020B-DE	
	For 400 V servo motors without brake SGMEV-(02/03/04/07/08/15)D□A□1-OY	3 m	R88A-CAWK003S-DE	
		5 m	R88A-CAWK005S-DE	
		10 m	R88A-CAWK010S-DE	
		15 m	R88A-CAWK015S-DE	
20 m		R88A-CAWK020S-DE		
For 400 V servo motors without brake SGMEV-(02/03/04/07/08/15)D□A□C-OY	3 m	R88A-CAWK003B-DE		
	5 m	R88A-CAWK005B-DE		
	10 m	R88A-CAWK010B-DE		
	20 m	R88A-CAWK020B-DE		
For 400 V servo motors without brake SGMGV-(03/05)D□A□1-OY	3 m	JZSP-VVM21-03-E		
	5 m	JZSP-VVM21-05-E		
	10 m	JZSP-VVM21-10-E		
	20 m	JZSP-VVM21-20-E		
For 400 V servo motors with brake SGMGV-(03/05)D□A□C-OY	3 m	JZSP-VVM41-03-E		
	5 m	JZSP-VVM41-05-E		
	10 m	JZSP-VVM41-10-E		
	20 m	JZSP-VVM41-20-E		

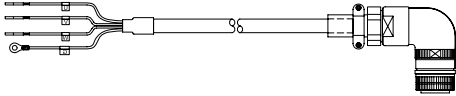
Symbol	Specifications	Model	Appearance	
	For 400 V servo motors SGMGV-09D□A□□-OY SGMSV-10D□A□□-OY	3 m	JZSP-CVMCA11-03-E-G1	
		5 m	JZSP-CVMCA11-05-E-G1	
		10 m	JZSP-CVMCA11-10-E-G1	
	For servomotors with brake, a separate cable (JZSP-CVB12-□□-E-G1) is needed	15 m	JZSP-CVMCA11-15-E-G1	
		20 m	JZSP-CVMCA11-20-E-G1	
	For 400 V servo motors SGMGV-(13/20)D□A□□-OY SGMSV-(15/20/25)D□A□□-OY	3 m	JZSP-CVMCA12-03-E-G1	
		5 m	JZSP-CVMCA12-05-E-G1	
		10 m	JZSP-CVMCA12-10-E-G1	
		15 m	JZSP-CVMCA12-15-E-G1	
		20 m	JZSP-CVMCA12-20-E-G1	
	For servomotors with brake, a separate cable (JZSP-CVB12-□□-E-G1) is needed	3 m	JZSP-CVMCA13-03-E-G1	
		5 m	JZSP-CVMCA13-05-E-G1	
10 m		JZSP-CVMCA13-10-E-G1		
15 m		JZSP-CVMCA13-15-E-G1		
20 m		JZSP-CVMCA13-20-E-G1		

Brake cable (for SGMGV-09/13/20/30/44 and SGMSV-10/15/20/25/30/40/50 Motors)

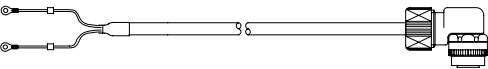
Symbol	Specifications	Model	Appearance	
⑤	Brake cable only. For 400 V servo motors with brake SGMGV-(09/13/20/30/44)D□A□C-OY SGMSV-(10/15/20/25/30/40/50)D□A□C-OY	3 m	JZSP-CVB12-03-E-G1	
		5 m	JZSP-CVB12-05-E-G1	
		10 m	JZSP-CVB12-10-E-G1	
		15 m	JZSP-CVB12-15-E-G1	
		20 m	JZSP-CVB12-20-E-G1	

Connectors for power and encoder cables

Description		Applicable Servo motor	Manufacturer	Model	Appearance
Power connector kit	Servomotor side	SGMJV-(A5/01)□, SGMJV-(A5/01)□, SGMJV-C2□	J.S.T.	JZSP-CSM9-1-E-G1	
		SGMJV-(02/04)□, SGMJV-(02/04/06)□	J.S.T.	JZSP-CSM9-2-E-G1	
		SGMJV-08□, SGMJV-(08/10)□	J.S.T.	JZSP-CSM9-3-E-G1	
		SGMGV-(03/05)□	Japan Aviation Electronics Industry, Ltd	JZSP-VVM9-1-E	
		SGMGV-(09/13/20)□, SGMSV-(10/15/20/25)□	DDK	CE-05-8A18-10SD-D-BAS	
		SGMGV-(30/44)□, SGMSV-(30/40/50)□	DDK	CE-05-8A22-22SD-D-BAS	
		SGMEV-□□A□	Hypertac	SPOC-06K-FSDN169	
		SGMEV-□□D□	Hypertac	LPRA-06B-FRBN170	
Brake connector kit	Servomotor side	SGMGV-(09/13/20/30/44)□, SGMSV-(10/15/20/25/30/40/50)□	DDK	CM10-AP2S-S-D	
Encoder connector kit	Servo drive side	SGMJV-□, SGMJV-□, SGMJV-□, SGMEV-□	Molex	JZSP-CMP9-1-E-G1	
	Servomotor side	SGMJV-□, SGMJV-□	Molex	JZSP-CSP9-2-E-G1	
		SGMGV-□, SGMSV-□	DDK	CM10-AP10S-M-D	
		SGMEV-□	Hypertac	SPOC-17H-FRON169	
Power connector kit - spare part connector male -	Servomotor side (connector included with 200 V models SGMJV motors)	SGMEV-□□A□	Hypertac	SRUC-06J-MSCN236	
Power connector kit - spare part connector male -	Servomotor side (connector included with 400 V models SGMJV motors)	SGMEV-□□D□	Hypertac	LRRA-06A-MRPN182	
Encoder connector kit - spare part connector male -	Servomotor side (connector included with SGMJV motors)	SGMEV-□	Hypertac	SRUC-17G-MRWN087	

Note: all connectors and cables listed have IP67 protection.
A crimping tool is required

Three-phase, 400 VAC

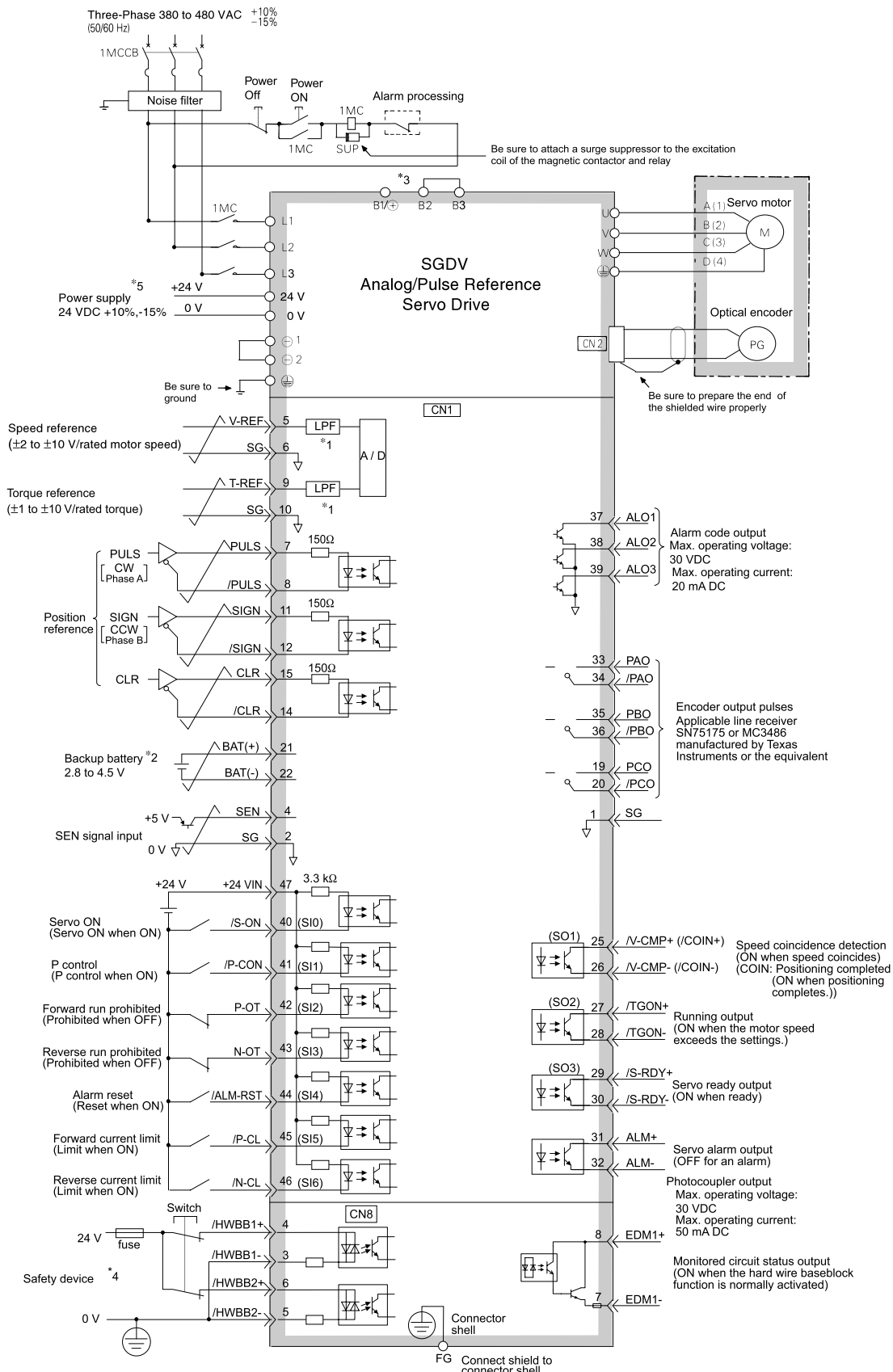

- *1 The time constant for the primary filter is 30 μ s.
- *2 Connect when using an absolute encoder. When the encoder cable for the battery case is connected, do not connect a backup battery.
- *3 Normally short B2 and B3. If the internal regenerative resistor is insufficient, remove the wire between B2 and B3 and connect an external regenerative resistor between B1 and B2.
- *4 For servo ON, connect to safety device and set wiring to enable safety function. When not using the safety function, use the servo drive with the plug (JZSP-CVH05-E, provided as an accessory) inserted into the CN8.
- *5 It is the user's responsibility to obtain 24 VDC power supply.

Single-phase, 230 VAC

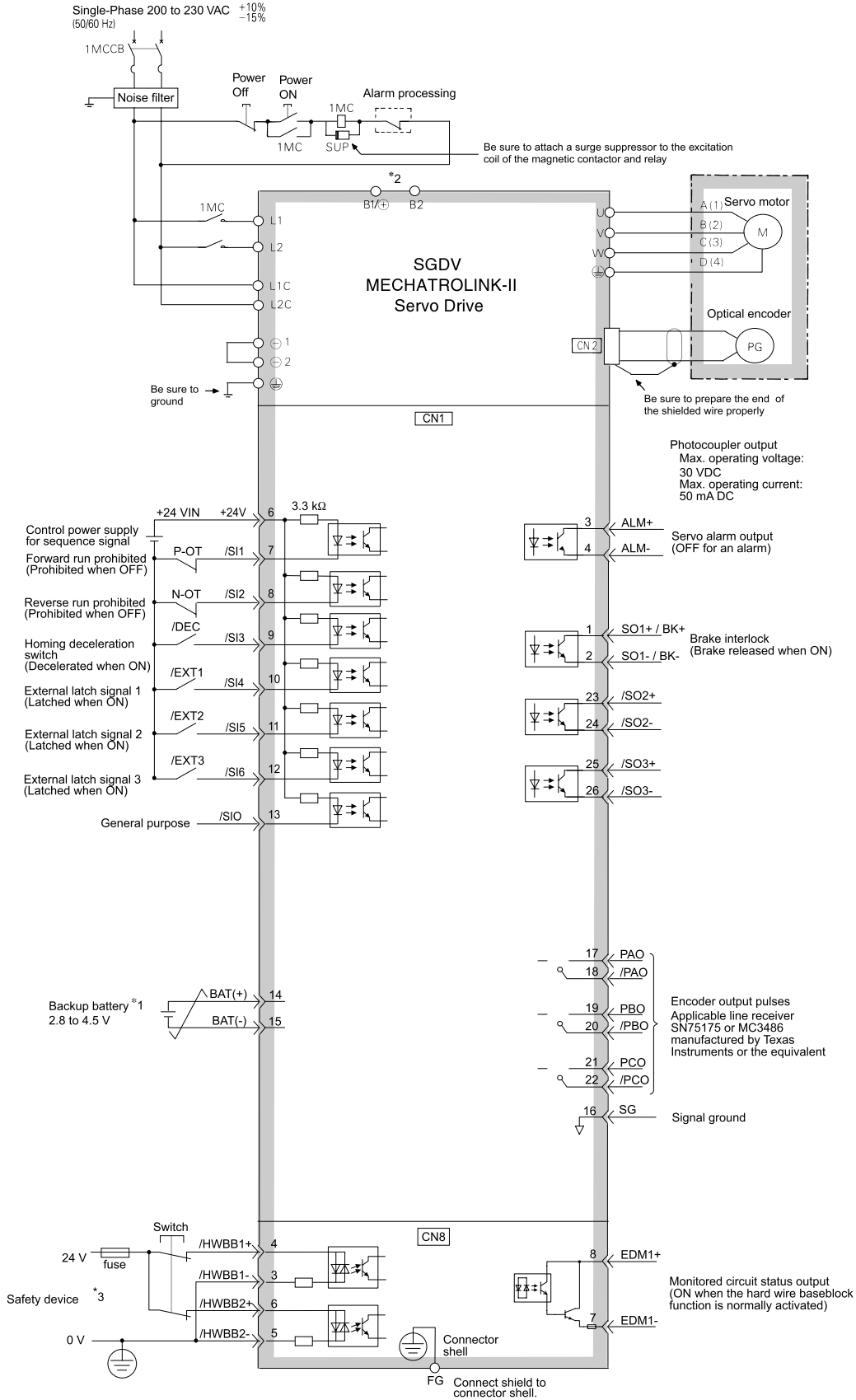

*1 Connect when using an absolute encoder. When the encoder cable for the battery case is connected, do not connect a backup battery.

*2 Regenerative resistor can be connected between B1 and B2. For 750 W servo drives types normally short B2 and B3.

*3 For servo ON, connect to safety device and set wiring to enable safety function. When not using the safety function, use the servo drive with the plug (JZSP-CVH05-E, provided as an accessory) inserted into the CN8.

Three-phase, 400 VAC

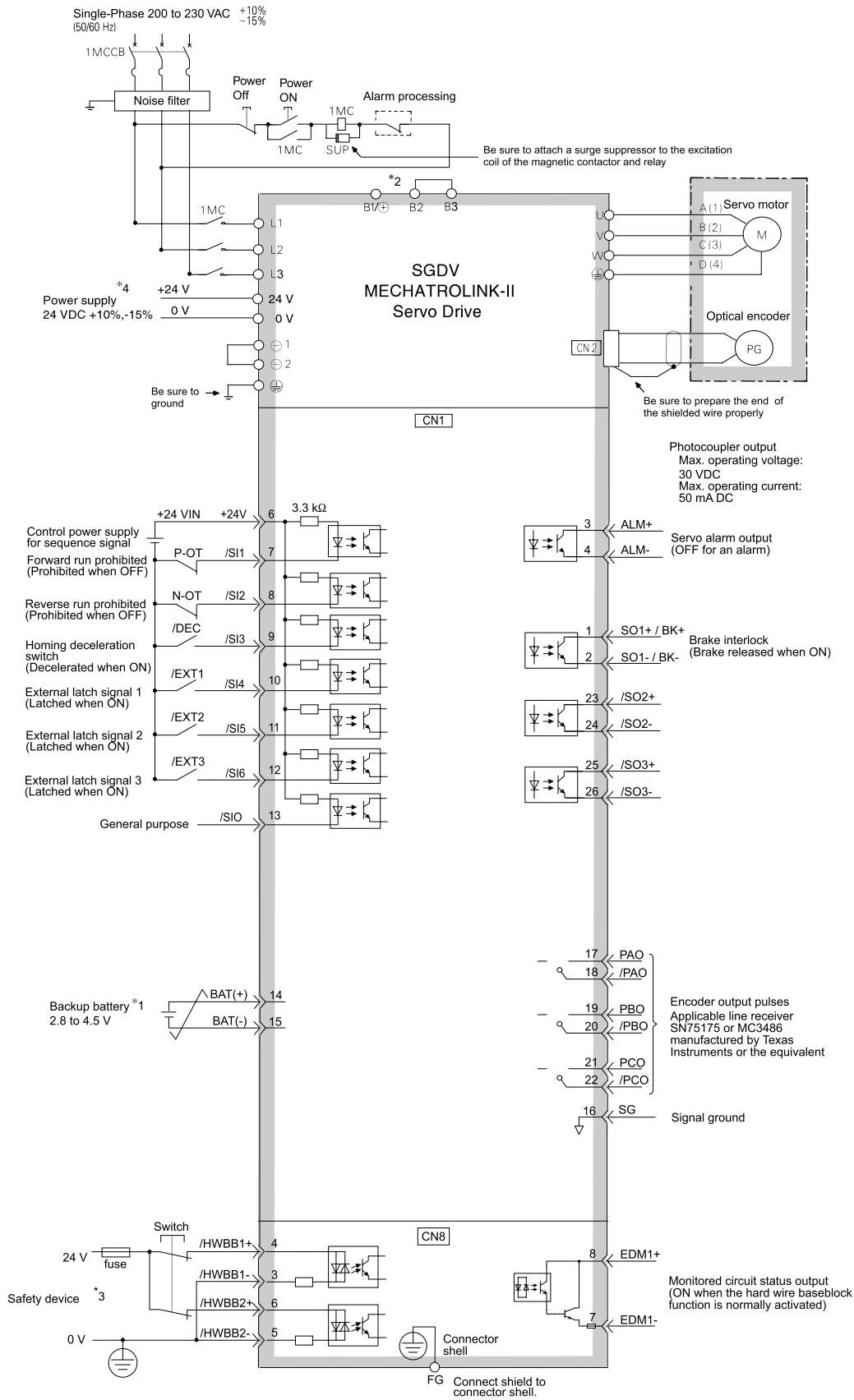

- *1 Connect when using an absolute encoder. When the encoder cable for the battery case is connected, do not connect a backup battery.
- *2 Normally short B2 and B3. If the internal regenerative resistor is insufficient, remove the wire between B2 and B3 and connect an external regenerative resistor between B1 and B2.
- *3 For servo ON, connect to safety device and set wiring to enable safety function. When not using the safety function, use the servo drive with the plug (JZSP-CVH05-E, provided as an accessory) inserted into the CN8.
- *4 It is the user's responsibility to obtain 24 VDC power supply.

Ordering information

Sigma-5 Analog/Pulse Reference Configuration

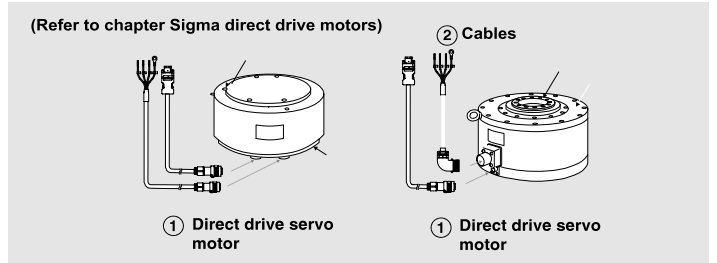
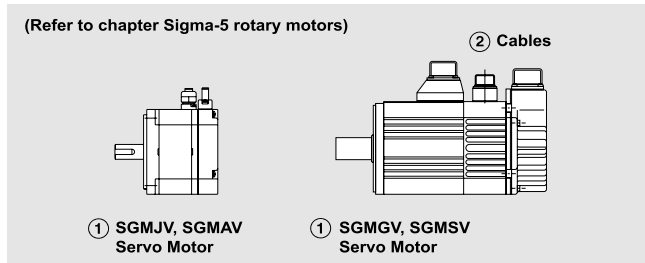
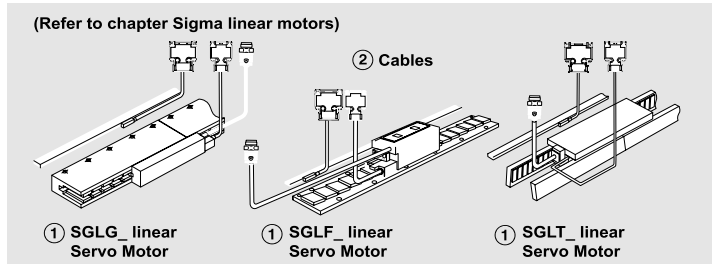
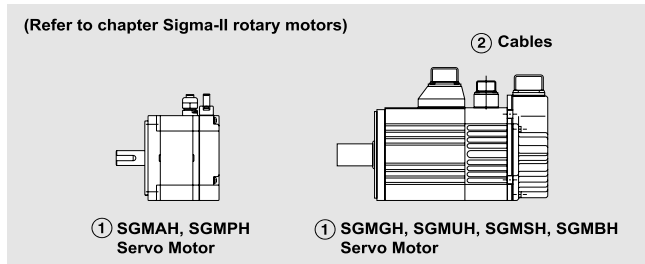
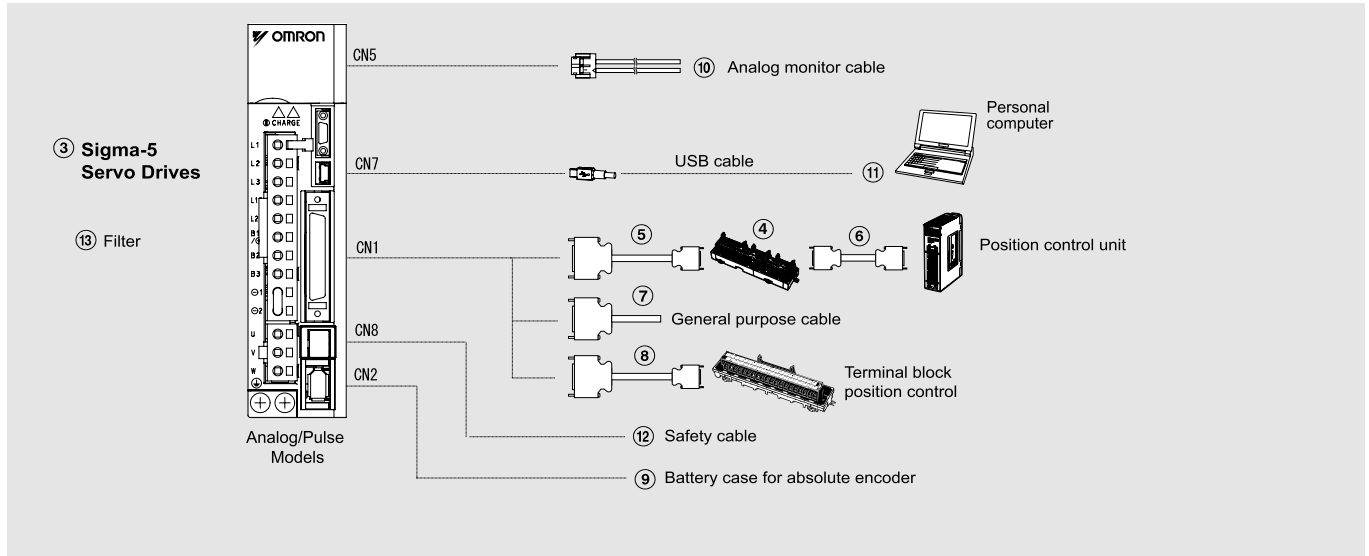

Note: The symbols ①②③④⑤... show the recommended sequence to select the components in a Sigma-5 servo system

Servo motors, power & encoder cables

Note: ①② Refer to the servo motors chapter for detailed motor specifications and selection

Servo drives

Symbol	Specifications	Model	Compatible rotary servo motors ①	Compatible direct drive motors ①	Compatible linear motors ①		
③	1 phase 230 VAC	50 W	SGDV-A5A01A-OY	SGMAH-A5D□, SGMJV-A5A□, SGMAV-A5A□	-	-	
			SGDV-A5A05A-OY	-	-	SGLGW-30A050□	
		100 W	SGDV-01A01A-OY	SGMAH-01A□, SGMPH-01A□, SGMJV-01A□, SGMAV-01A□, SGMEV-01A□	-	-	-
			SGDV-01A05A-OY	-	-	SGLGW-30A080□, SGLGW-40A140□	
		200 W	SGDV-02A01A-OY	SGMAH-02A□, SGMPH-02A□, SGMJV-02A□, SGMAV-02A□, SGMEV-02A□	SGMCS-07B□	-	-
			SGDV-02A05A-OY	-	-	SGLGW-60A140□, SGLGW-40A253□, SGLFW-20A□, SGLFW-35A120□	
		400 W	SGDV-04A01A-OY	SGMAH-04A□, SGMPH-04A□, SGMJV-04A□, SGMAV-04A□, SGMEV-04A□	SGMCS-02B□, SGMCS-05B□, SGMCS-04C□, SGMCS-10C□, SGMCS-14C□, SGMCS-08D□, SGMCS-17D□, SGMCS-25D□	-	-
			SGDV-04A05A-OY	-	-	SGLGW-40A365□, SGLGW-60A253A□	
		750 W	SGDV-08A01A-OY	SGMAH-08A□, SGMPH-08A□, SGMJV-08A□, SGMAV-08A□, SGMEV-08A□	SGMCS-16E□, SGMCS-35E□	-	-
			SGDV-08A05A-OY	-	-	SGLGW-60A365A□, SGLFW-35A230□, SGLFW-50A200□	
	1.5 kW	SGDV-15A01A-OY	SGMPH-15A□, SGMAV-10A□, SGMEV-15A□	SGMCS-45M□, SGMCS-80M□, SGMCS-80N□	-	-	
		SGDV-15A05A-OY	-	-	SGLGW-90A200A□, SGLFW-50A380□, SGLFW-1ZA200□		
	3 phase 400 VAC	0.5 kW	SGDV-05D01A-OY	SGMAH-03D□, SGMPH-04D□, SGMGH-05D□, SGMEV-04D□, SGMGV-05D□	-	-	
			SGDV-05D05A-OY	-	-	SGLFW-35D□	
		1.0 kW	SGDV-10D01A-OY	SGMAH-07D□, SGMPH-08D□, SGMGH-09D□, SGMSH-10D□, SGMUH-10D□, SGMEV-08D□, SGMGV-09D□, SGMSV-10D□	-	-	-
			SGDV-10D05A-OY	-	-	SGLFW-50D200□, SGLTW-35D170□, SGLTW-50D170□	
		1.5 kW	SGDV-15D01A-OY	SGMPH-15D□, SGMGH-13D□, SGMSH-15D□, SGMUH-15D□, SGMEV-15D□, SGMGV-13D□, SGMSV-15D□	-	-	-
			SGDV-15D05A-OY	-	-	SGLFW-50D380□, SGLFW-1ZD200□	
		2 kW	SGDV-20D01A-OY	SGMGH-20D□, SGMSH-20D□, SGMGV-20D□, SGMSV-20D□	-	-	-
			SGDV-20D05A-OY	-	-	SGLFW-1ED380□, SGLTW-35D320□, SGLTW-50D320□	
3 kW		SGDV-30D01A-OY	SGMGH-30D□, SGMSH-30D□, SGMUH-30D□, SGMGV-30D□, SGMGV-30D□	-	-	-	
		SGDV-30D05A-OY	-	-	SGLFW-1ZD380□, SGLFW-1ED560□, SGLTW-40D400□		
5 kW	SGDV-50D01A-OY	SGMGH-44D□, SGMSH-50D□, SGMUH-40D□, SGMGV-44D□, SGMSV-50D□	-	-	-		
	SGDV-50D05A-OY	-	-	SGLTW-40D60□, SGLTW-80D400□			

Control cables (for CN1)

Symbol	Description	Connect to		Model
④	Servo relay unit	CJ1W-NC1□3		XW2B-20J6-1B (1 axis)
		CJ1W-NC2□3/4□3		XW2B-40J6-2B (2 axis)
		CJ1M-CPU22/23		XW2B-20J6-8A (1 axis)
				XW2B-40J6-9A (2 axis)
⑤	Cable to servo drive	Servo relay units XW2B-□0J6-□B	1 m	XW2Z-100J-B4
			2 m	XW2Z-200J-B4
⑥	Position control unit connecting cable	CJ1W-NC113	0.5 m	XW2Z-050J-A14
			1 m	XW2Z-100J-A14
		CJ1W-NC213/413	0.5 m	XW2Z-050J-A15
			1 m	XW2Z-100J-A15
		CJ1W-NC133	0.5 m	XW2Z-050J-A18
			1 m	XW2Z-100J-A18
		CJ1W-NC233/433	0.5 m	XW2Z-050J-A19
			1 m	XW2Z-100J-A19
⑦	Control cable	For general purpose controllers	1 m	R88A-CPW001S
			2 m	R88A-CPW002S
⑧	Relay terminal block cable	General purpose controller	1 m	R88A-CTW001N
			2 m	R88A-CTW002N
	Relay terminal block		-	XW2B-50G5

Battery backup for absolute encoder (for CN2 encoder cable)

Symbol	Name	Model
⑨	Battery	JZSP-BA01

Note: when the encoder cables with a battery case are used, no battery is required for CN1 (between pin 21 and 22). Battery for CN1 is ER6VCN3.

Cable (for CN5)

Symbol	Name	Model
⑩	Analog monitor cable	R88A-CMW001S
		DE9404559

USB personal computer cable (for CN7)

Symbol	Name	Note
⑪	USB Mini Connector cable	JZSP-CVS06-02-E

Note: double shield USB cable recommended

Cable for Safety Functions (for CN8)

Symbol	Name	Model
⑫	Safety connector with 3 m cable (with Loose Wires at one End)	JZSP-CVH03-03-E

Note: when using the safety function, connect this cable to the safety devices. Even when not using the safety function, use servo drive with the Safe Jumper Connector (JZSP-CVH05-E) connected.

Filters

Symbol	Applicable servo drive	Filter model	Rated current	Rated voltage
⑬	SGDV-A5A□□A-OY,SGDV-A01□□A-OY, SGDV-01A□□A-OY, SGDV-04A□□A-OY	R88A-FI5-1005-RE	5 A	250 VAC single-phase
	SGDV-08A□□A-OY	R88A-FI5-1009-RE	9 A	
	SGDV-15A□□A-OY	R88A-FI5-1016-RE	16 A	
	SGDV-05D□□A-OY, SGDV-10D□□A-OY, SGDV-15D□□A-OY	R88A-FI5-3004-RE	4.3 A	400 VAC three-phase
	SGDV-20D□□A-OY, SGDV-30D□□A-OY	R88A-FI5-3008-RE	8.6 A	
	SGDV-50D□□A-OY	R88A-FI5-3012-RE	14.5 A	

Connectors

Specifications	Model
I/O connector kit (for CN1)	R88A-CNU11C
Sigma-5 drive encoder connector (for CN2)	JZSP-CMP9-1
Safe Jumper Connector	JZSP-CVH05-E

Computer software

Specifications	Model
Configuration and monitoring software tool for servo drives and inverters. (CX-drive version 1.50 or higher)	CX-drive
Complete OMRON software package including CX-drive. (CX-One version 3.0.2 or higher)	CX-One

Ordering information

Sigma-5 MECHATROLINK Servo Drive Configuration

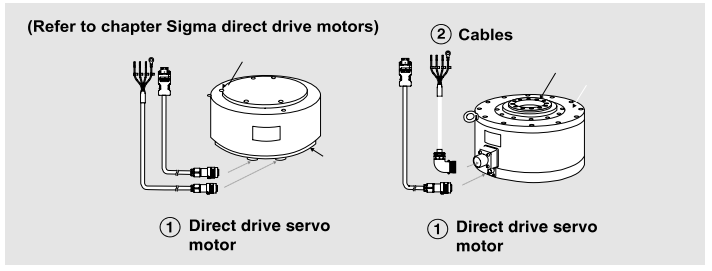
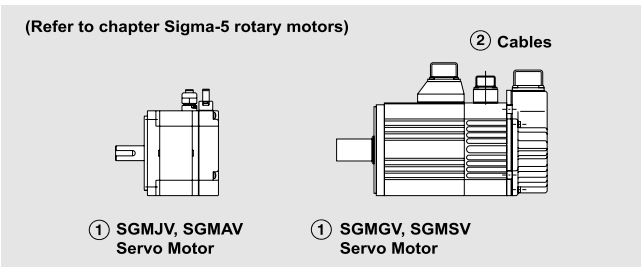
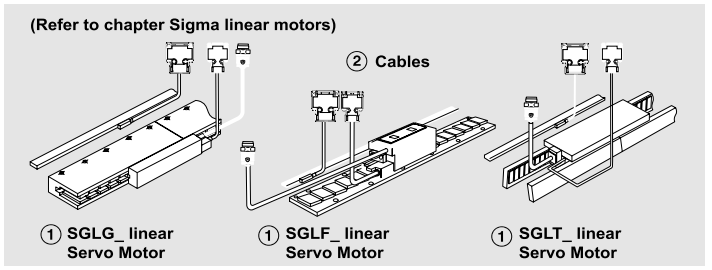
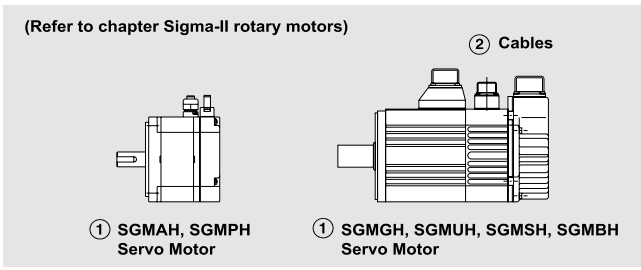
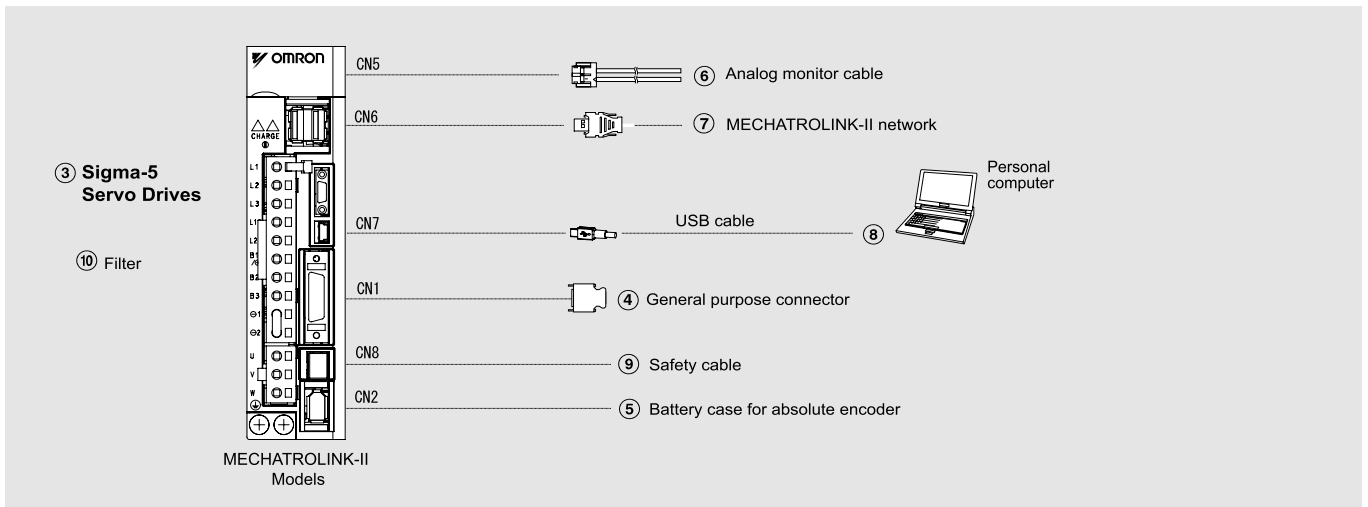

Note: The symbols ①②③④⑤... show the recommended sequence to select the components in a Sigma-5 servo system

Servo motors, power & encoder cables

Note: ①② Refer to the servo motors chapter for detailed motor specifications and selection

Servo drives

Symbol	Specifications	Model	Compatible rotary servo motors ①	Compatible direct drive motors ①	Compatible linear motors ①		
③	1 phase 230 VAC	50 W	SGDV-A5A11A-OY	SGMAH-A5D□, SGMJV-A5A□, SGMAV-A5A□	-	-	
			SGDV-A5A15A-OY	-	-	SGLGW-30A050□	
		100 W	SGDV-01A11A-OY	SGMAH-01A□, SGMPH-01A□, SGMJV-01A□, SGMAV-01A□, SGMEV-01A□	-	-	-
			SGDV-01A15A-OY	-	-	-	SGLGW-30A080□, SGLGW-40A140□
		200 W	SGDV-02A11A-OY	SGMAH-02A□, SGMPH-02A□, SGMJV-02A□, SGMAV-02A□, SGMEV-02A□	SGMCS-07B□	-	-
			SGDV-02A15A-OY	-	-	-	SGLGW-60A140□, SGLGW-40A253□, SGLFW-20A□, SGLFW-35A120□
		400 W	SGDV-04A11A-OY	SGMAH-04A□, SGMPH-04A□, SGMJV-04A□, SGMAV-04A□, SGMEV-04A□	SGMCS-02B□, SGMCS-05B□, SGMCS-04C□, SGMCS-10C□, SGMCS-14C□, SGMCS-08D□, SGMCS-17D□, SGMCS-25D□	-	-
			SGDV-04A15A-OY	-	-	-	SGLGW-40A365□, SGLGW-60A253A□
		750 W	SGDV-08A11A-OY	SGMAH-08A□, SGMPH-08A□, SGMJV-08A□, SGMAV-08A□, SGMEV-08A□	SGMCS-16E□, SGMCS-35E□	-	-
			SGDV-08A15A-OY	-	-	-	SGLGW-60A365A□, SGLFW-35A230□, SGLFW-50A200□
		1.5 kW	SGDV-15A11A-OY	SGMPH-15A□, SGMAV-10A□, SGMEV-15A□	SGMCS-45M□, SGMCS-80M□, SGMCS-80N□	-	-
			SGDV-15A15A-OY	-	-	-	SGLGW-90A200A□, SGLFW-50A380□, SGLFW-1ZA200□
	3 phase 400 VAC	0.5 kW	SGDV-05D11A-OY	SGMAH-03D□, SGMPH-04D□, SGMGH-05D□, SGMEV-04D□, SGMGV-05D□	-	-	
			SGDV-05D15A-OY	-	-	-	SGLFW-35D□
		1.0 kW	SGDV-10D11A-OY	SGMAH-07D□, SGMPH-08D□, SGMGH-09D□, SGMSH-10D□, SGMUH-10D□, SGMEV-08D□, SGMGV-09D□, SGMSV-10D□	-	-	-
			SGDV-10D15A-OY	-	-	-	SGLFW-50D200□, SGLTW-35D170□, SGLTW-50D170□
		1.5 kW	SGDV-15D11A-OY	SGMPH-15D□, SGMGH-13D□, SGMSH-15D□, SGMUH-15D□, SGMEV-15D□, SGMGV-13D□, SGMSV-15D□	-	-	-
			SGDV-15D15A-OY	-	-	-	SGLFW-50D380□, SGLFW-1ZD200□
		2 kW	SGDV-20D11A-OY	SGMGH-20D□, SGMSH-20D□, SGMGV-20D□, SGMSV-20D□	-	-	-
			SGDV-20D15A-OY	-	-	-	SGLFW-1ED380□, SGLTW-35D320□, SGLTW-50D320□
		3 kW	SGDV-30D11A-OY	SGMGH-30D□, SGMSH-30D□, SGMUH-30D□, SGMGV-30D□, SGMGV-30D□	-	-	-
			SGDV-30D15A-OY	-	-	-	SGLFW-1ZD380□, SGLFW-1ED560□, SGLTW-40D400□
		5 kW	SGDV-50D11A-OY	SGMGH-44D□, SGMSH-50D□, SGMUH-40D□, SGMGV-44D□, SGMSV-50D□	-	-	-
			SGDV-50D15A-OY	-	-	-	SGLTW-40D60□, SGLTW-80D400□

Battery backup for absolute encoder (for CN2 encoder cable)

Symbol	Name	Model
⑤	Battery	JZSP-BA01

Note: when the encoder cables with a battery case JZSP-BA01 are used, no battery is required for CN1 (between pin 21 and 22). Battery for CN1 is ER6VCN3.

Cable (for CN5)

Symbol	Name	Model
⑥	Analog monitor cable	R88A-CMW001S
		DE9404559

Mechatrolink-II cables (for CN6)

Symbol	Specifications	Length	Model
⑦	Mechatrolink-II Terminator resistor		JEPMC-W6022
	Mechatrolink-II Cables	0.5 m	JEPMC-W6003-A5
		1 m	JEPMC-W6003-01
		3 m	JEPMC-W6003-03
		5 m	JEPMC-W6003-05
		10 m	JEPMC-W6003-10
		20 m	JEPMC-W6003-20
30 m	JEPMC-W6003-30		

Filters

Symbol	Applicable servo drive	Filter model	Rated current	Rated voltage
⑩	SGDV-A5A□□A-OY,SGDV-A01□□A-OY, SGDV-01A□□A-OY, SGDV-04A□□A-OY	R88A-FI5-1005-RE	5 A	250 VAC single-phase
	SGDV-08A□□A-OY	R88A-FI5-1009-RE	9 A	
	SGDV-15A□□A-OY	R88A-FI5-1016-RE	16 A	
	SGDV-05D□□A-OY, SGDV-10D□□A-OY, SGDV-15D□□A-OY	R88A-FI5-3004-RE	4.3 A	400 VAC three-phase
	SGDV-20D□□A-OY, SGDV-30D□□A-OY	R88A-FI5-3008-RE	8.6 A	
	SGDV-50D□□A-OY	R88A-FI5-3012-RE	14.5 A	

Connectors

Specification	Model
I/O connector kit (for CN1)	R88A-CNW01C
Sigma-5 drive encoder connector (for CN2)	JZSP-CMP9-1
Safe Jumper Connector	JZSP-CVH05-E

Computer software

Specifications	Model
Configuration and monitoring software tool for servo drives and inverters. (CX-drive version 1.50 or higher)	CX-drive
Complete OMRON software package including CX-drive. (CX-One version 3.0.2 or higher)	CX-One

USB personal computer cable (for CN7)

Symbol	Name	Note
⑧	USB Mini Connector cable	JZSP-CVS06-02-E

Note: double shield USB cable recommended

Cable for Safety Functions (for CN8)

Symbol	Name	Model
⑨	Safety connector with 3 m cable (with Loose Wires at one End)	JZSP-CVH03-03-E

Note: when using the safety function, connect this cable to the safety devices. Even when not using the safety function, use servo drive with the Safe Jumper Connector (JZSP-CVH05-E) connected.

ALL DIMENSIONS SHOWN ARE IN MILLIMETERS.
To convert millimeters into inches, multiply by 0.03937. To convert grams into ounces, multiply by 0.03527.